

NOTE:

- 1) VALVE BOX SHALL NOT BE SUPPORTED BY THE WATER LINE.
- 2) VALVE BOX TO BE PLUMB AND CENTERED OVER NUT.
- 3) VALVE BOX DETAIL SHALL APPLY TO BOTH NEW INSTALLATION & ADJUSTMENT OF EXISTING VALVES.
- 4) THE MAXIMUM DISTANCE THAT THE SCREW-IN RISER MAY EXTEND ABOVE THE TOP SECTION, WHEN INITIALLY INSTALLED, SHALL BE 1½ INCHES.
- 5) WHEN ADJUSTING EXISTING VALVE BOXES, RECONNECT EXISTING TRACING WIRE IF PRESENT.

VALVE BOX DETAIL

NTS



NOTES:

- 1) PLUG SHALL BE MECHANICALLY RESTRAINED:
- 2) 2" BLOW OFF PIPING MAY BE BRASS WITH THREADED BRASS FITTINGS OR TYPE K SOFT COPPER WITH BRONZE THREADED x COMPRESSION FITTINGS.

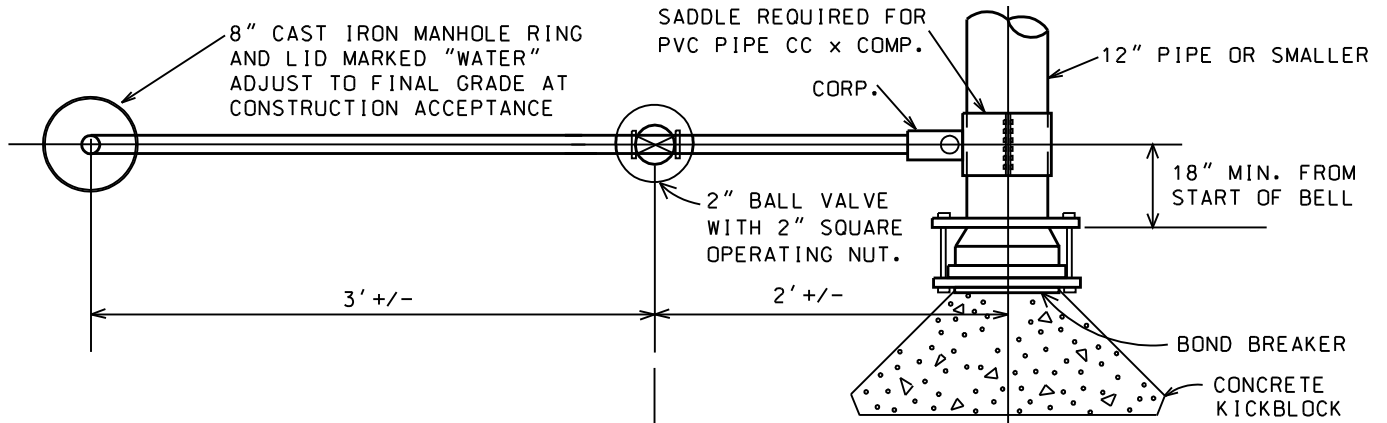

PLAN

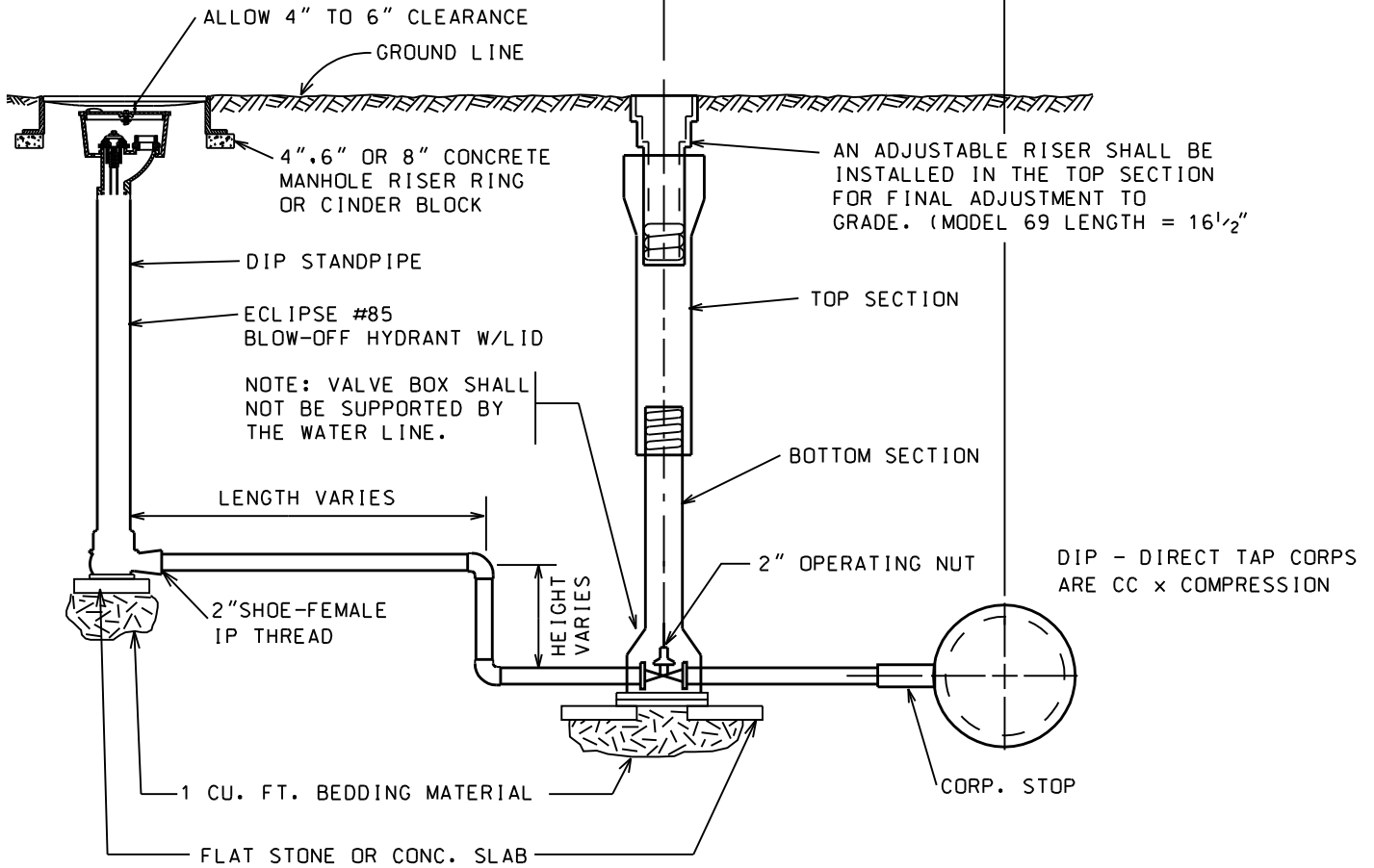

ELEVATION

STD. BLOW-OFF INSTALLATION FOR 12" & SMALLER PIPE

NTS



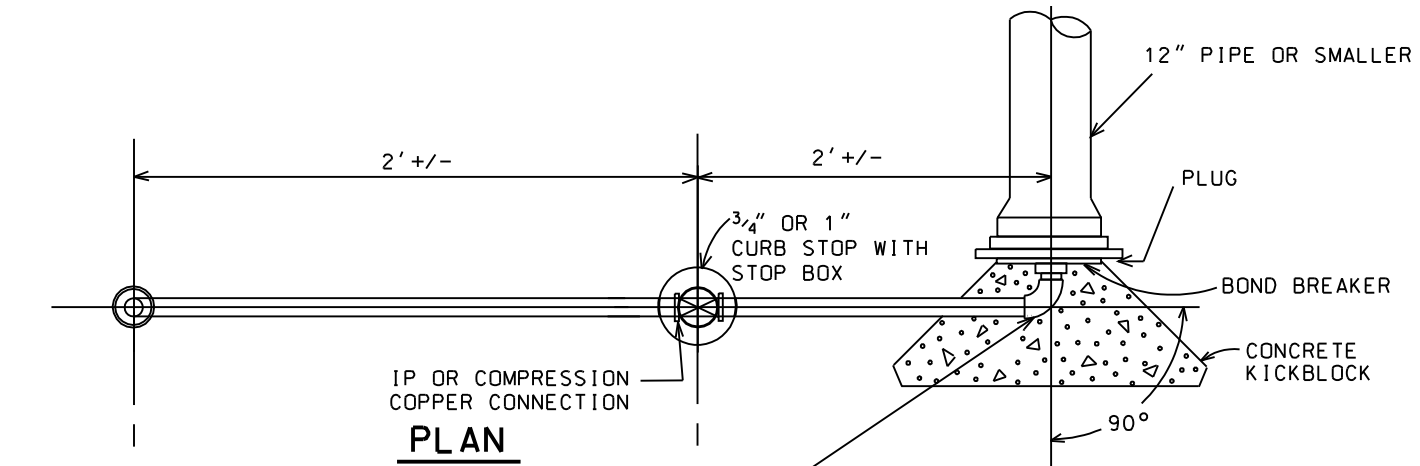

PLAN

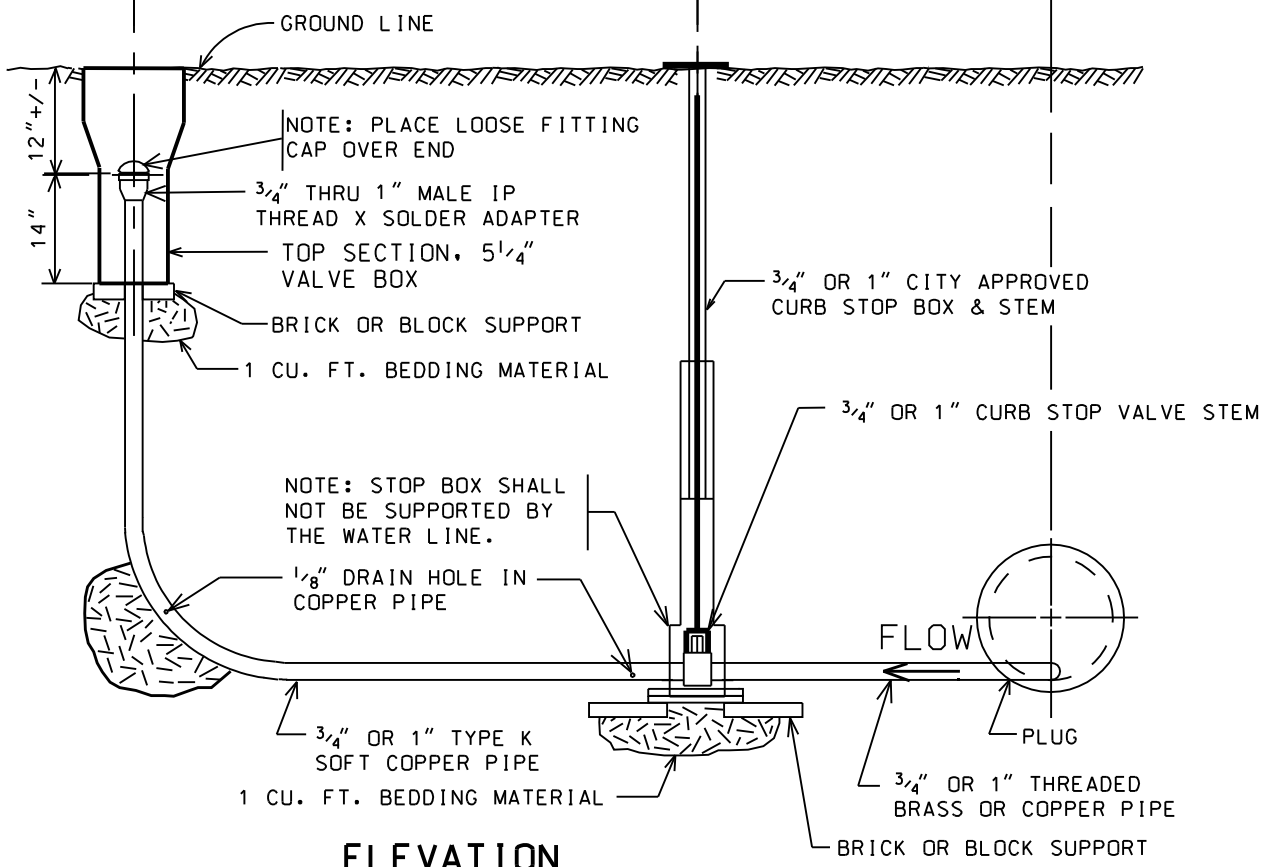

ELEVATION

**TEMPORARY 3/4" & 1" BLOW-OFF
INSTALLATION FOR 12" & SMALLER PIPE**

NTS

REV.	DATE	BY	APPROVED
7-18-02		JR/AM	
10-10-02		JR	



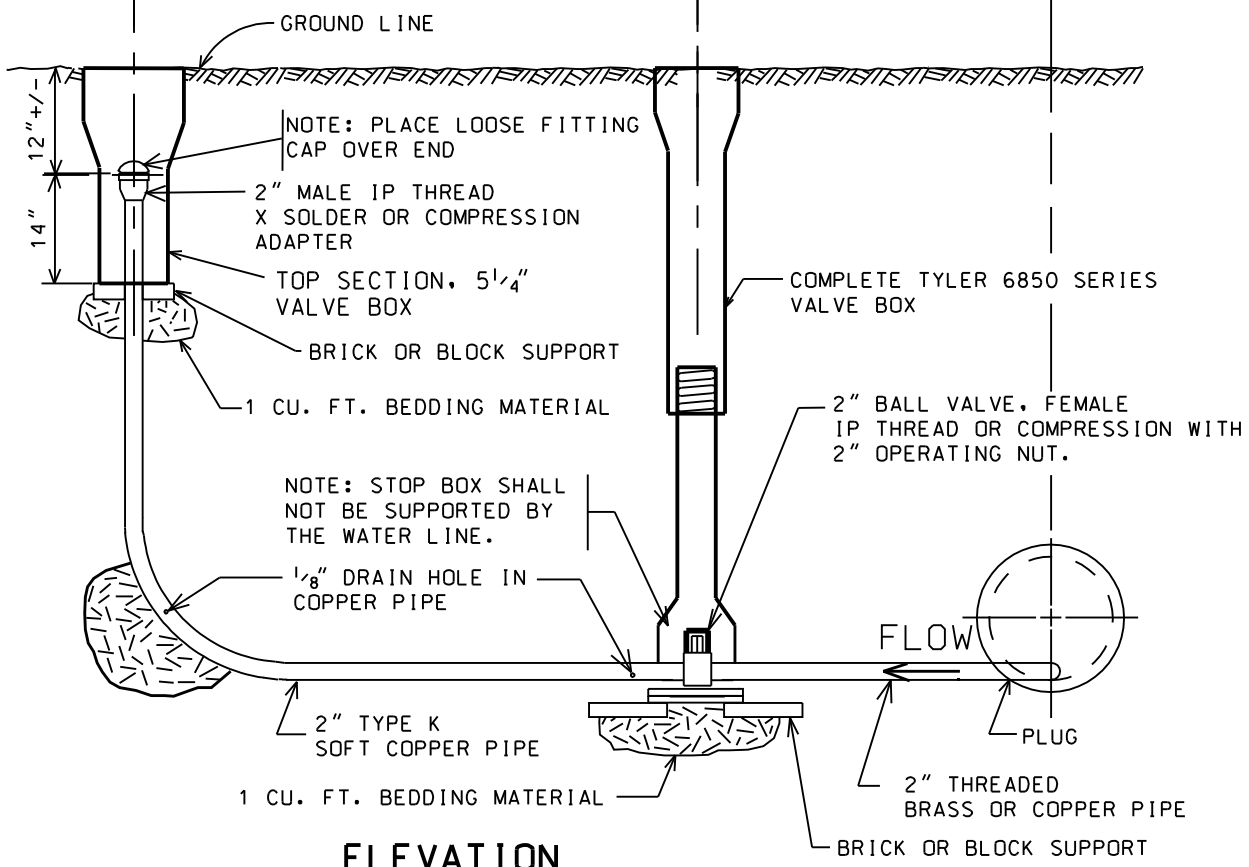
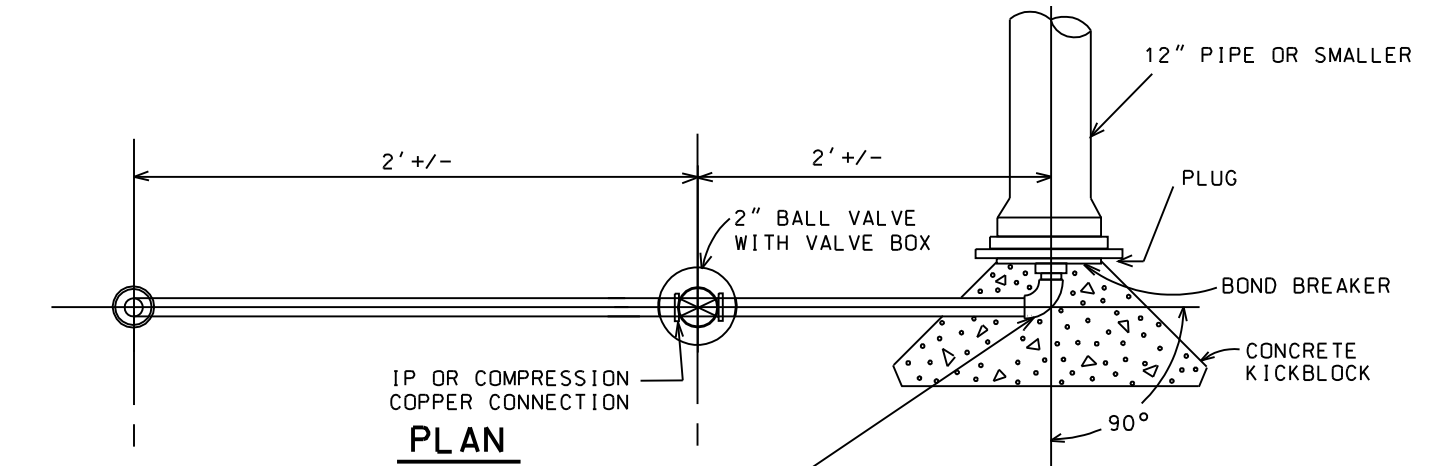

**TEMPORARY 2" BLOW-OFF
INSTALLATION FOR 12" & SMALLER PIPE**

NTS

REV.	DATE	BY	APPROVED
7-18-02		JR/AM	
10-10-02		JR	



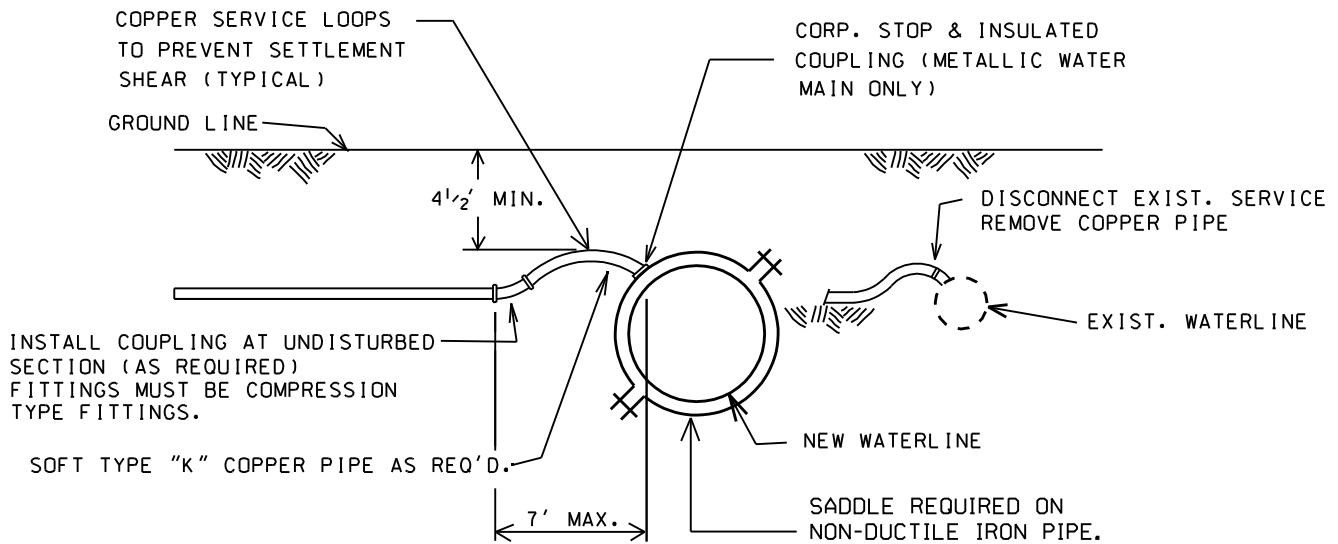

SERVICE RECONNECT (SHORT)

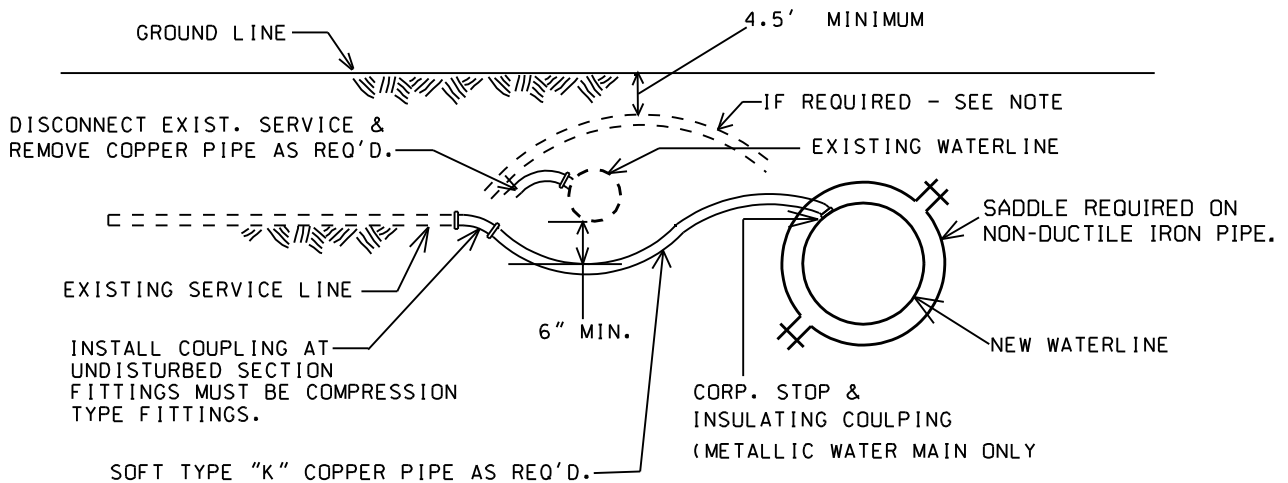

SERVICE RECONNECT (LONG)

NOTE:

IF THE EXISTING WATERLINE IS AT SUCH A DEPTH THAT THE NEW LONG SERVICE CAN BE INSTALLED OVER THE EXISTING WATERLINE AND STILL MAINTAIN 4' - 6" MINIMUM GROUND COVER, THE SERVICE MAY BE CONNECTED AS SHOWN IN THE ABOVE DETAIL. THE CONTRACTOR SHALL OBTAIN APPROVAL FROM THE ENGINEER PRIOR TO CONSTRUCTING THE SERVICE CONNECTION IN THIS MANNER.

WATER SERVICE LINE RECONNECTS

NTS



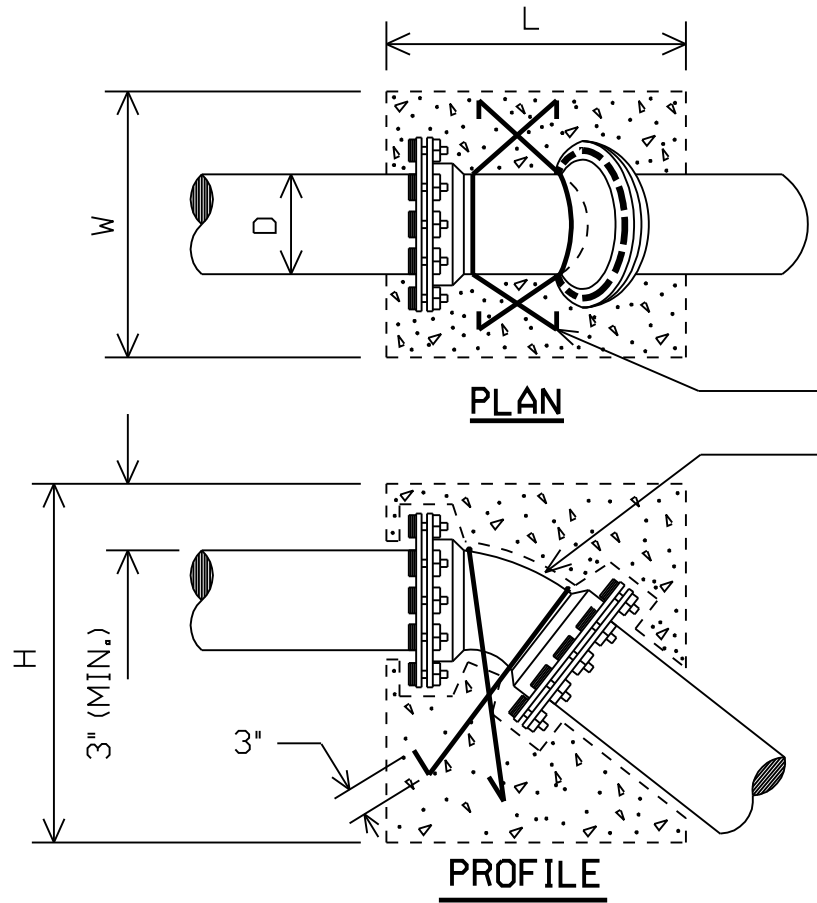

#5 REBARS LOOPED OVER BEND. EMBEDMENT LENGTH IN CONCRETE IS EQUAL TO (E) IN TABLE BELOW.

BONDBREAKER (TYPICAL)

REBARS EXPOSED TO EARTH SHALL BE COATED WITH BITUMINOUS PAINT.

SIZE OF PIPE (D)	11 1/4 DEG.					22 1/2 DEG.					45 DEG.				
	L"	W"	H"	E"	VOL	L"	W"	H"	E"	VOL	L"	W"	H"	E"	VOL
4"	12	24	24	12	4	12	34	34	12	8	22	37	32	22	15
6"	18	32	27	18	9	15	52	40	15	18	28	64	32	28	33
8"	21	40	33	21	16	22	61	40	22	31	35	64	45	35	58
10"	24	50	36	24	25	30	59	48	30	49	42	72	52	42	90
12"	31	56	36	31	36	36	70	48	36	70	45	80	62	45	129

NOTES:

- 1) VOLUME IS IN CUBIC FEET.
- 2) ALL CONCRETE TO BE 2,500 P.S.I. MIN.
- 3) BLOCKS TO BE CENTERED HORIZONTALLY ON THE BEND.
- 4) DESIGN BASED ON A TEST PRESSURE OF 150 P.S.I. AND SAFETY FACTOR (S_f) OF 1.5

THE DESIGN ENGINEER IS RESPONSIBLE FOR VERIFYING THE ACTUAL SITE CONDITIONS WITH RESPECT TO THE ASSUMPTIONS LISTED ABOVE.

$$5) V_g = \frac{S_f PA \sin \theta}{W_m}$$

$$6) W_m = 140 \# / FT^3$$

UPPER VERTICAL THRUST BLOCK DETAIL



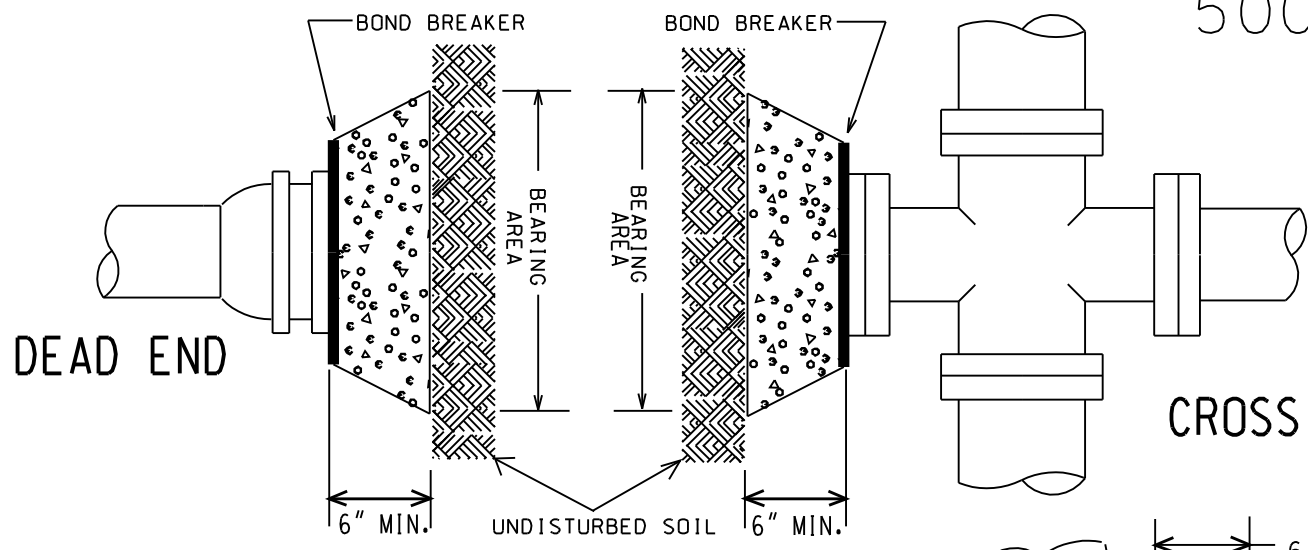

NOTES:

1. BEARING SURFACES SHOWN IN CHART ARE MINIMUM
2. THE CHART IS BASED ON 150 PSI POTENTIAL PIPE PRESSURE PLUS A 1.5 SAFETY FACTOR
3. SOIL BEARING CAPACITY = 1,500 LB/SQ. FT. (ASSUMED)
4. THRUST IS EQUAL TO $[S_f (2)PA \sin \theta/2]$ FOR A BEND
5. THRUST IS EQUAL TO $[PA S_f]$ FOR A TEE OR DEAD END
6. BEARING AREA IS THRUST DIVIDED BY SOIL BEARING CAPACITY
7. THE DESIGN ENGINEER IS RESPONSIBLE FOR VERIFYING THE ACTUAL SITE CONDITIONS WITH RESPECT TO THE ASSUMPTIONS LISTED ABOVE.

MINIMUM BEARING SURFACE AREA
(IN SQUARE FEET)

SIZE OF PIPE	BENDS				TEE OR DEAD END
	11¼ DEG	22½ DEG	45 DEG	90 DEG	
4"	1	1	2	3	2
6"	1	2	4	6	5
8"	2	3	6	11	8
10"	3	5	10	17	12
12"	4	7	13	24	17

NOTE: THESE NUMBERS ARE ROUNDED UP TO THE NEXT WHOLE NUMBER.

THESE NUMBERS WILL VARY DEPENDING ON THE BEARING CAPACITY OF THE SOIL.

BLOCK HEIGHT SHOULD BE EQUAL TO OR LESS THAN 1/2 THE TOTAL DEPTH TO THE BOTTOM OF THE BLOCKS, BUT NO LESS THAN THE PIPE DIAMETER. ALSO THE WIDTH MUST BE BETWEEN ONE AND TWO TIMES THE HEIGHT.

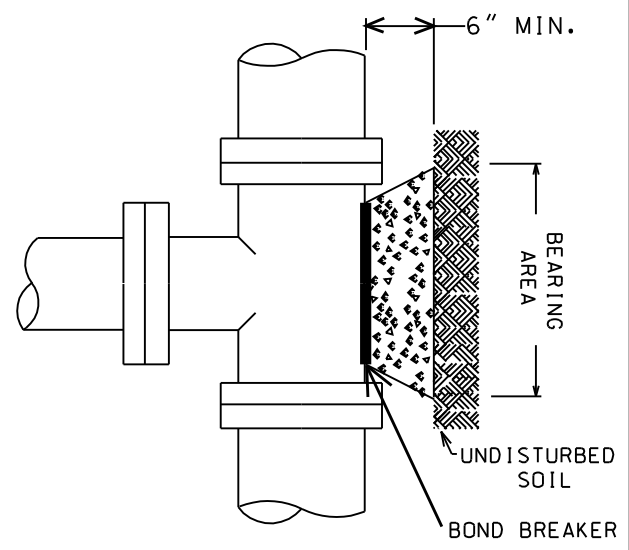
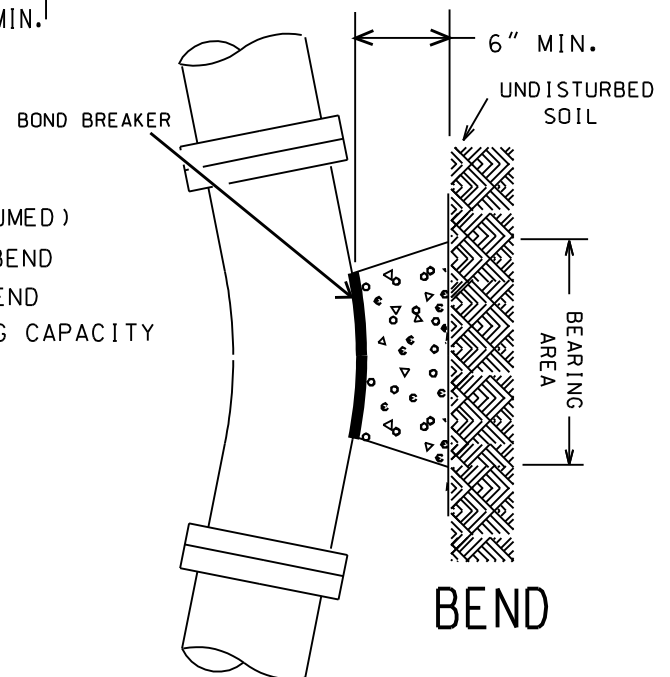

HORIZONTAL THRUST BLOCK DETAIL

NTS



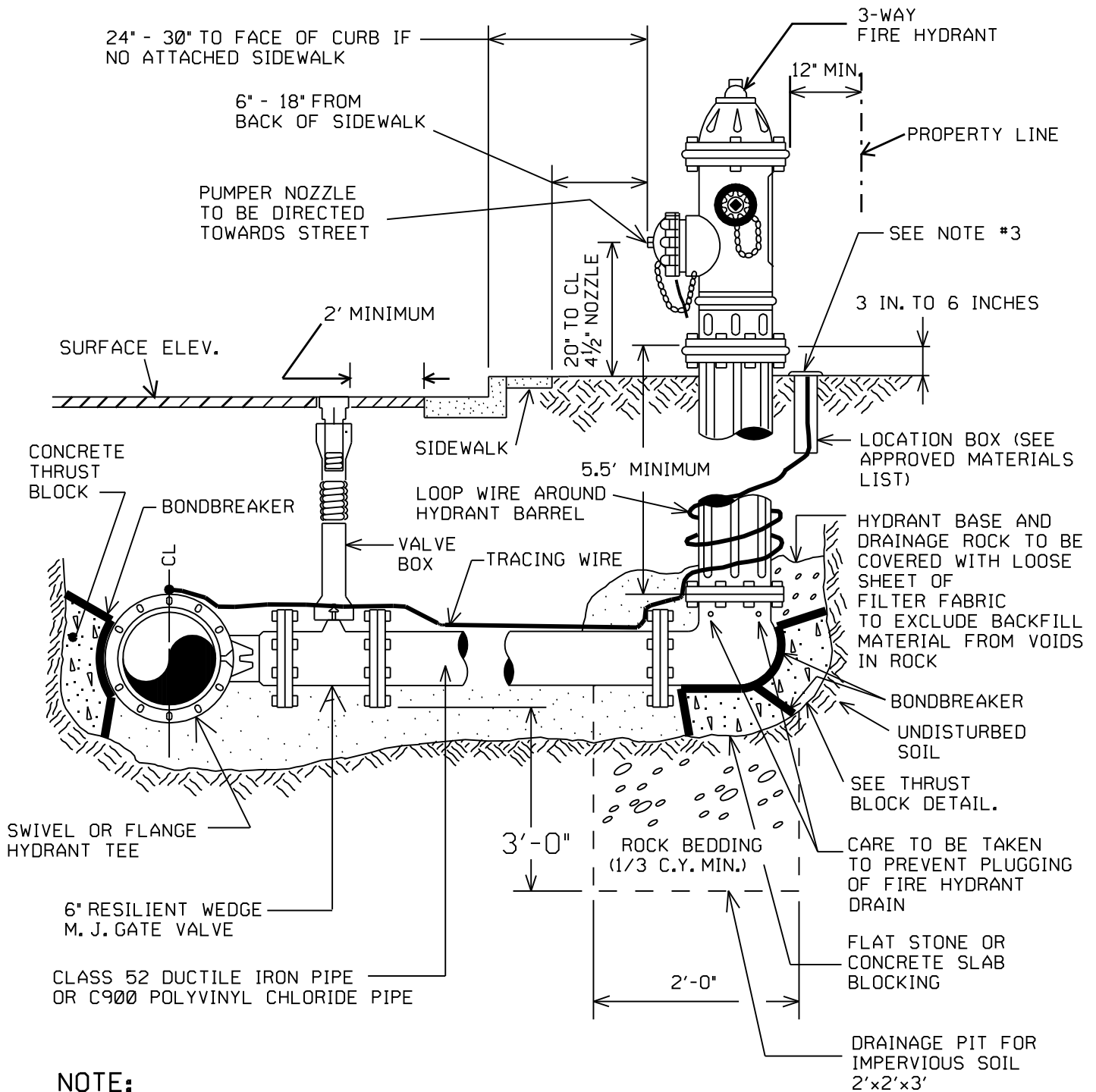

NOTE:

- 1) IF MORE THAN ONE BARREL EXTENSION IS USED TO RAISE A FIRE HYDRANT TO GRADE, ONLY ONE STEM EXTENSION OF THE PROPER LENGTH WILL BE ALLOWED. MULTIPLE STEM EXTENSIONS ARE NOT ACCEPTABLE.
- 2) ALL METALIC PIPE MUST BE WRAPPED IN POLYETHYLENE INCLUDING HYDRANT BARREL.
- 3) A MINIMUM OF 12 INCHES OF SLACK SHALL BE INSTALLED FOR EACH WIRE IN THE LOCATION BOX
- 4) ADDITIONAL TRACING WIRE STATIONS MAY BE NECESSARY IF FIRE HYDRANT SPACING IS TO GREAT TO ADEQUATELY TRACE THE PIPELINE.

**STANDARD FIRE HYDRANT
INSTALLATION PROFILE**

NTS



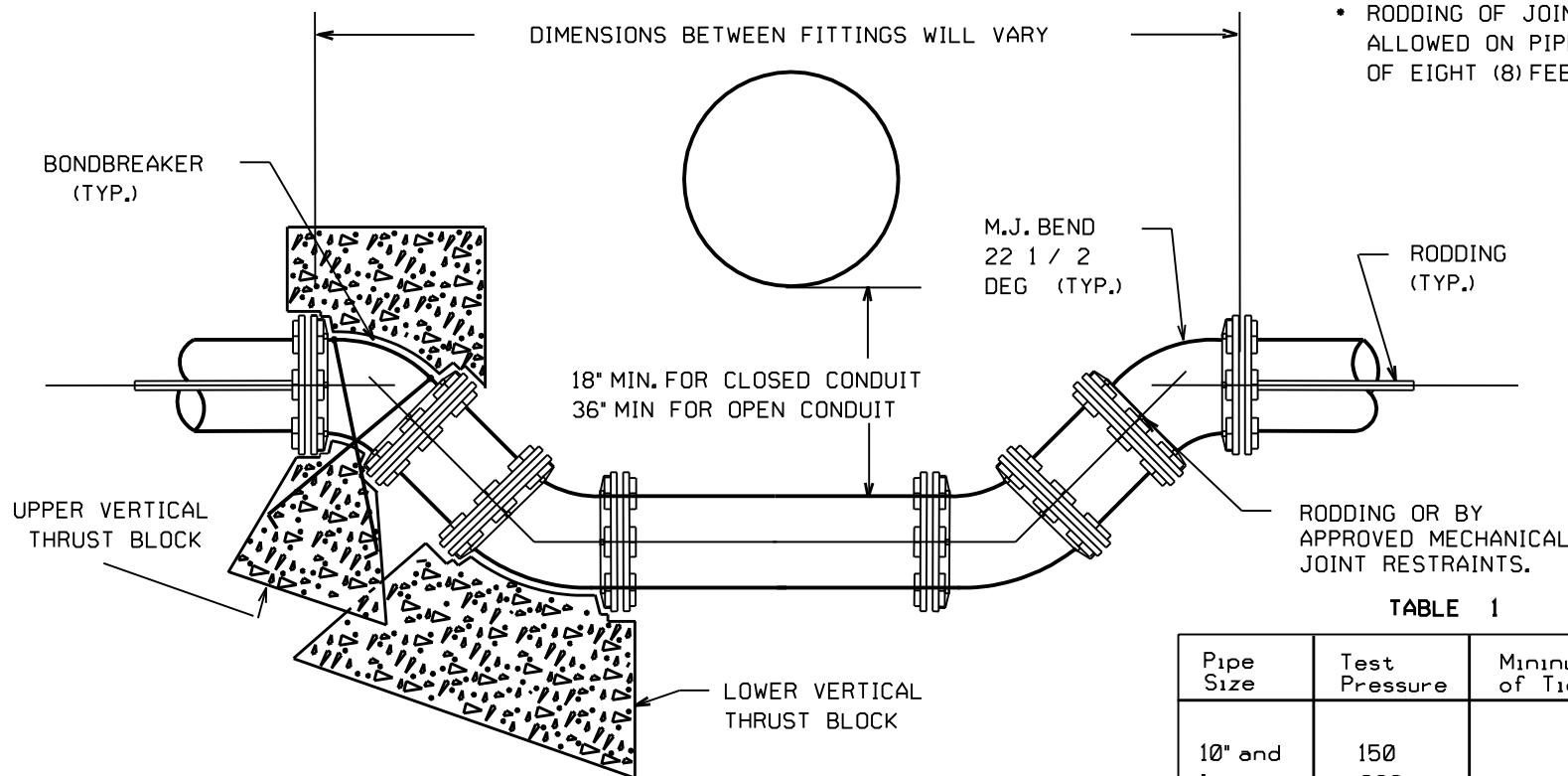

• RODDING OF JOINTS IS NOT ALLOWED ON PIPE SECTIONS OF EIGHT (8) FEET OR LONGER.

TABLE 1

Pipe Size	Test Pressure	Minimum number of Tie Rods
10" and less	150	2
	200	2
12"	150	2
	200	4

NOTES:

- 1) LOWERING OF THIS TYPE MAY BE RESTRAINED BY MEANS OF THRUST BLOCKING OR BY RODDING OF THE JOINTS OR BY APPROVED MECHANICAL JOINT RESTRAINTS.
- 2) FOR SIZING INFORMATION OF THRUST BLOCKS REFER TO THRUST BLOCK DETAILS.
- 3) WHEN RESTRAINING PIPE BY MEANS OF RODDING JOINTS, 3/4" TIE RODS, NUTS, AND WASHERS WILL BE USED AND ARE TO BE MADE OF "COR-TEN" STEEL GRADE #2 AS PER A.S.T.M. A242.

- 4) FOR FURTHER INFORMATION ON RODDING OF JOINTS REFER TO TABLE 1.
- 5) ALL METALIC PIPE, FITTINGS, AND APPURTENANCES WILL BE WRAPPED IN POLYETYLENE.
- 6) REQUIREMENTS FOR LARGER THAN 12" DIAMETER PIPE WILL BE DETERMINED ON A CASE BY CASE BASIS.
- 7) IF CONTINOUS LINE PRESSURE IS GREATER THAN 100 PSI, A COMBINATION OF RODDING / RESTRAINING GLANDS AND THRUST BLOCKS WILL BE REQUIRED.

12" OR SMALLER WATERLINE, LOWERING DETAIL FOR UTILITY CROSSINGS

NTS

REV 3-19-93 BM
REV 4-11-96 JR



500-07

METER YOLK MUST BE PERPENDICULAR TO MAIN

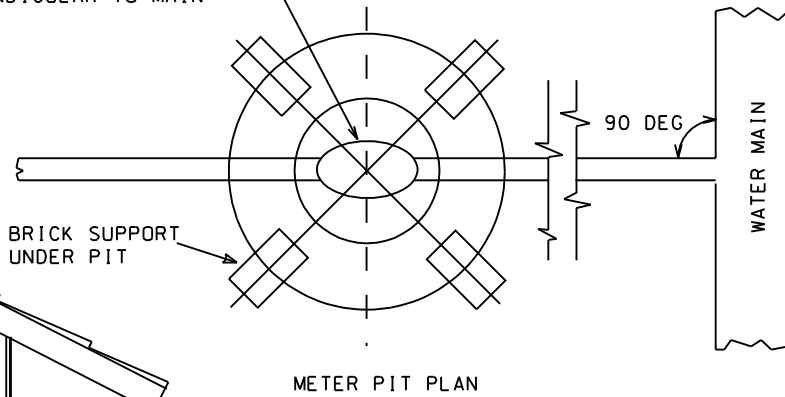

NOTES:

- 1) METERS & YOKES TO BE PURCHASED FROM THE CITY.
- 2) THE CITY WILL SUPPLY A TEMPORARY JUMPER BAR FOR THE METER PIT DURING CONSTRUCTION.
- 3) FITTINGS OUTSIDE THE STRUCTURE MUST BE COMPRESSION TYPE FITTINGS.
- 4) METER PITS SHALL BE LOCATED 5' OFF SIDE LOT LINES AND OUT OF DRIVEWAYS.
- 5) CONTRACTOR SHALL MARK THE LOCATION OF THE CURB STOP & BOX WITH A METAL T-POST EXTENDING A MINIMUM OF 4 FT. ABOVE THE GROUND.
- 6) IF INSTALLATION OF SERVICE LINE IS CONSTRUCTED BY "PUNCHING" UNDER AN EXISTING SIDEWALK/CURB & GUTTER, THEN CONTRACTOR MUST INSTALL A PVC SLEEVE UNDER SIDEWALK/CURB & GUTTER. DIAMETER OF PVC SLEEVE MUST BE WITHIN 1/4" OF "PUNCHED" HOLE.
- 7) ANY VARIATION OF LOCATION OF METER PITS AND ASSOCIATED APPURTENANCES MUST BE APPROVED BY THE ENGINEER.
- 8) METER PIT SHALL NOT BE INSTALLED AT THE TIME OF SERVICE LINE INSTALLATION.
- 9) REFER TO SEC 201.01 FOR RIGHT OF WAY LOCATION.
- 10) TOP OF LID TO BE EVEN WITH FINISH GRADE OF LANDSCAPING MATERIALS.

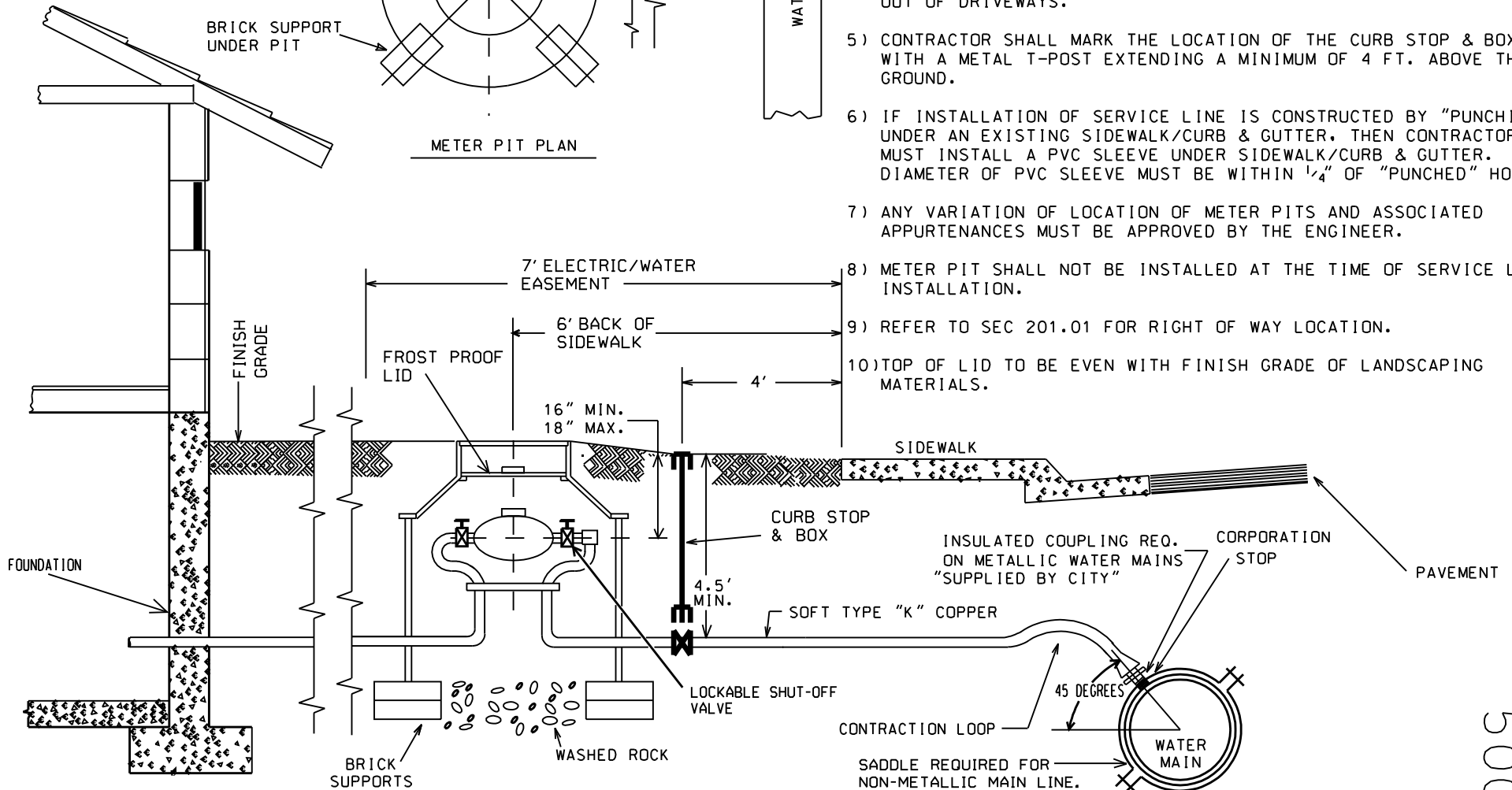

WATER SERVICE AND OUTSIDE METER INSTALLATION

NTS (ATTACHED SIDEWALK SHOWN)

REV 9-28-94 SC
REV 4-11-96 JR



500-08

METER YOLK MUST BE PERPENDICULAR TO MAIN

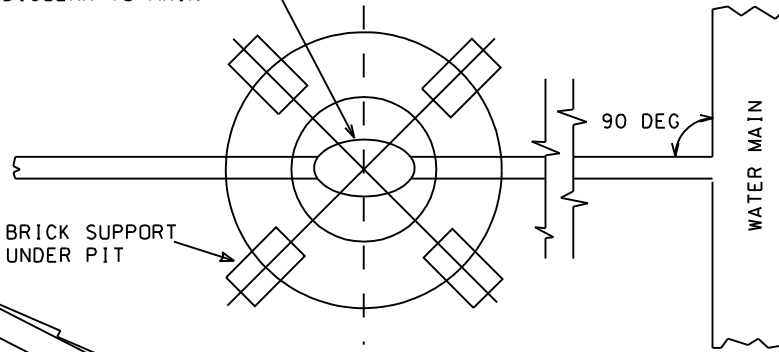

METER PIT PLAN

NOTES:

- 1) METERS & YOKES TO BE PURCHASED FROM THE CITY.
- 2) THE CITY WILL SUPPLY A TEMPORARY JUMPER BAR FOR THE METER PIT DURING CONSTRUCTION.
- 3) FITTINGS OUTSIDE THE STRUCTURE MUST BE COMPRESSION TYPE FITTINGS.
- 4) METER PITS SHALL BE LOCATED 5' OFF SIDE LOT LINES AND OUT OF DRIVEWAYS.
- 5) CONTRACTOR SHALL MARK THE LOCATION OF THE CURB STOP & BOX WITH A METAL T-POST EXTENDING A MINIMUM OF 4 FT. ABOVE THE GROUND.
- 6) IF INSTALLATION OF SERVICE LINE IS CONSTRUCTED BY "PUNCHING" UNDER AN EXISTING SIDEWALK/CURB & GUTTER, THEN CONTRACTOR MUST INSTALL A PVC SLEEVE UNDER SIDEWALK/CURB & GUTTER. DIAMETER OF PVC SLEEVE MUST BE WITHIN 1/4" OF "PUNCHED" HOLE.
- 7) ANY VARIATION OF LOCATION OF METER PITS AND ASSOCIATED APPURTENANCES MUST BE APPROVED BY THE ENGINEER.
- 8) METER PIT SHALL NOT BE INSTALLED AT THE TIME OF SERVICE LINE INSTALLATION.
- 9) REFER TO SEC 201.01 FOR RIGHT OF WAY LOCATION.
- 10) TOP OF LID TO BE EVEN WITH FINISH GRADE OF LANDSCAPING MATERIALS.

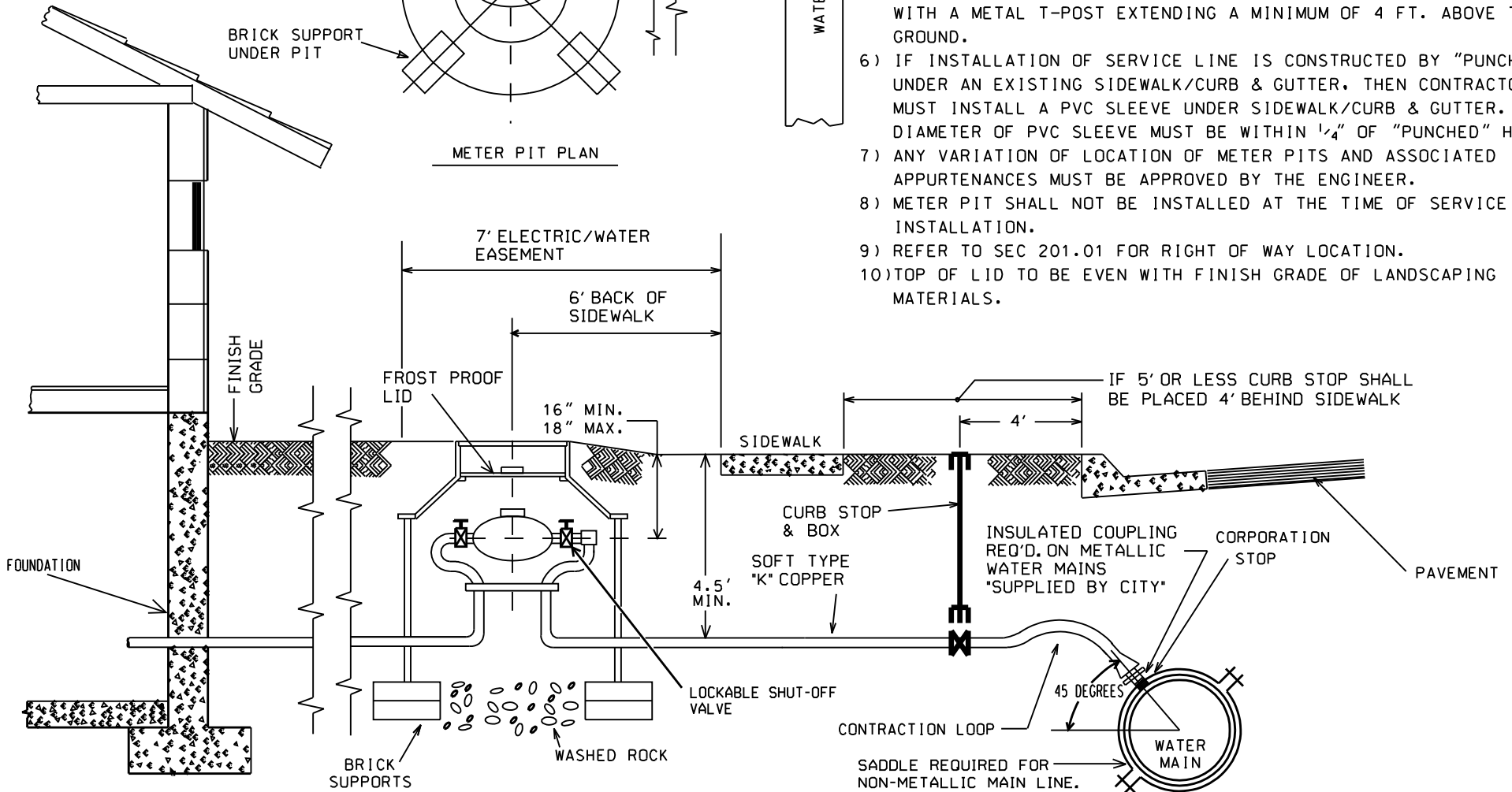

WATER SERVICE AND OUTSIDE METER INSTALLATION

NTS (DETACHED SIDEWALK SHOWN)



METER YOLK MUST BE PERPENDICULAR TO MAIN

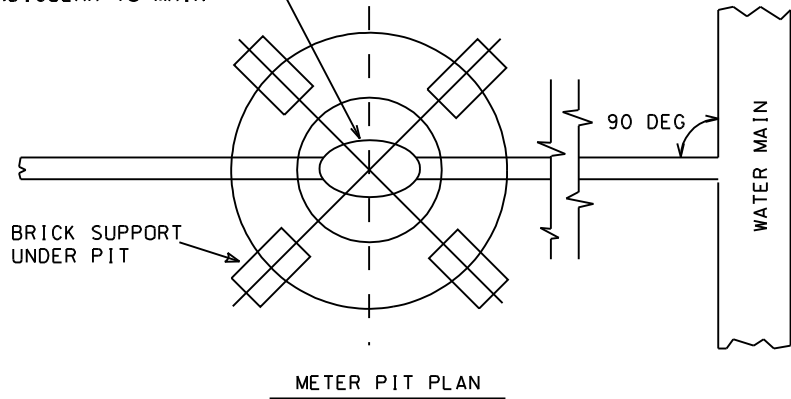

NOTES:

- 1) CONTRACTOR SHALL PLACE A TEMPORARY STEEL PLATE OVER THE PIT 12"-18" BELOW FINAL GRADE AND MARK THE LOCATION WITH A 2"x4" EXTENDING A MINIMUM OF 2 FT. ABOVE THE GROUND. (APPLIES ONLY WHEN PITS ARE INSTALLED DURING MAIN LINE CONSTRUCTION.) CONTRACTOR SHALL SET LID TO FINAL GRADE AFTER ELECTRICAL SYSTEM INSTALLATION.
- 2) METERS & YOKES TO BE PURCHASED FROM THE CITY.
- 3) THE CITY WILL SUPPLY A TEMPORARY JUMPER BAR FOR THE METER PIT DURING CONSTRUCTION.
- 4) FITTINGS OUTSIDE THE STRUCTURE MUST BE COMPRESSION TYPE FITTINGS.
- 5) CONTRACTOR SHALL MARK THE LOCATION OF THE CURB STOP & BOX WITH A METAL T-POST EXTENDING A MINIMUM OF 4 FT. ABOVE THE GROUND.
- 6) ANY VARIATION OF LOCATION OF METER PITS AND ASSOCIATED APPURTENANCES MUST BE APPROVED BY THE ENGINEER.
- 7) TOP OF LID TO BE EVEN WITH FINISH GRADE OF LANDSCAPING MATERIALS.

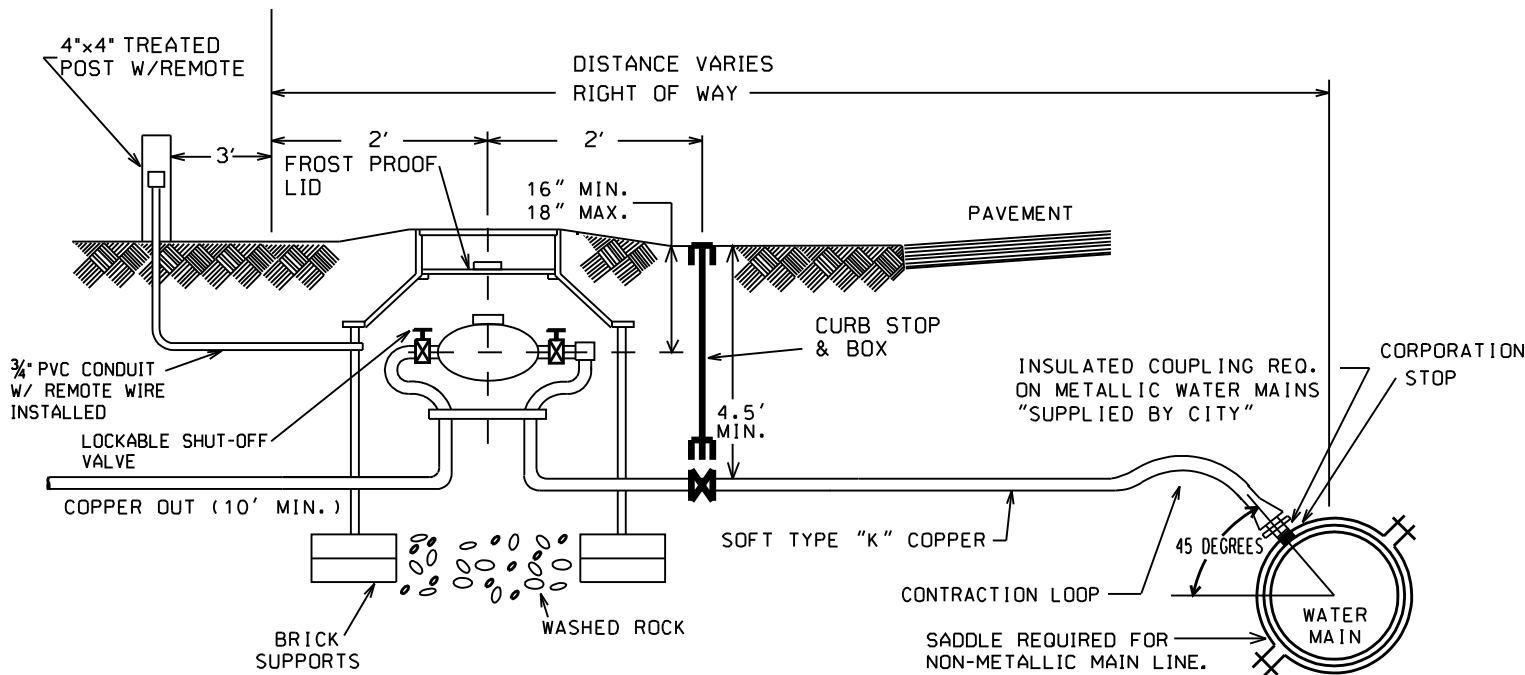

RURAL WATER SERVICE AND OUTSIDE METER INSTALLATION

NTS



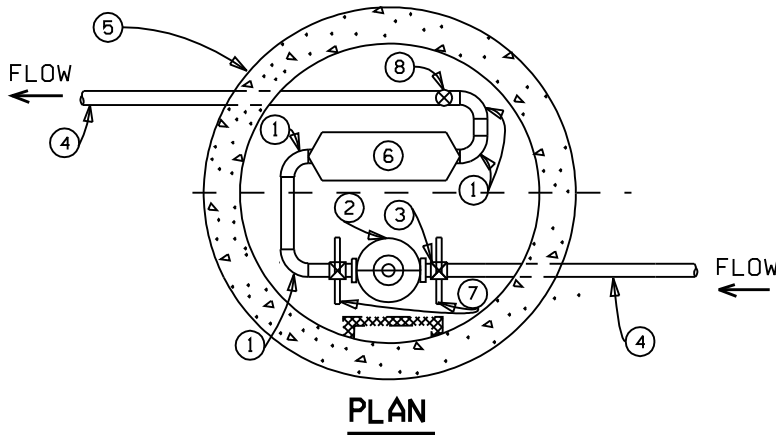

- ① - 90 DEG. ELBOW
- ② - METER UNIT
- ③ - APPROVED COPPERSETTER WITH BYPASS.
- ④ - TYPE K 'SOFT' COPPER TUBING
- ⑤ - 60" DIA. CONCRETE VAULT
- ⑥ - DOUBLE CHECK VALVE
- ⑦ - PIPE BRACE
- ⑧ - BALL VALVE
- ⑨ - 1" DRAINAGE HOLE WITH EXPANSION PLUG AND DRAINAGE PIT

8" ALUMINUM MANHOLE RING & LID W/ STAINLESS STEEL PENTAGON HEAD BOLT, WASHER & NUT.

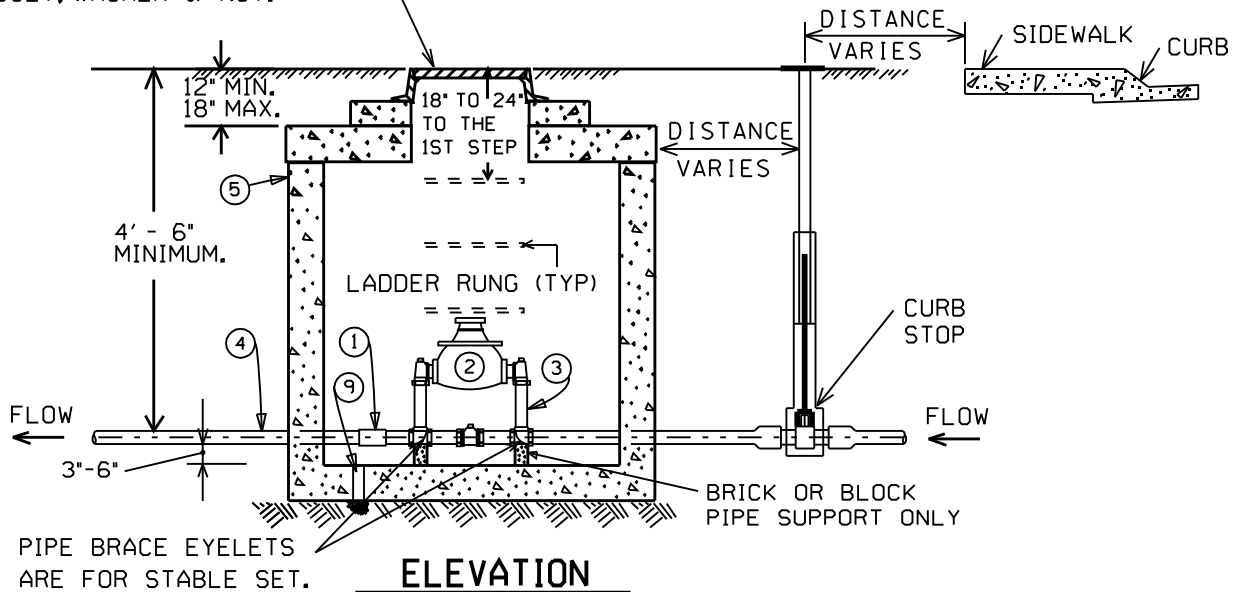

NOTES:

- 1-BASE AND BOTTOM BARREL SECTION SHALL BE PRECAST AS A SINGLE UNIT. THE VAULT SHALL BE WATERTIGHT. USE APPROVED GASKET MATERIALS TO SEAL PIPE PENETRATIONS.
- 2-A 60" DIA. VAULT WILL ACCOMMODATE A 2" METER. LARGER METERS WILL REQUIRE A SPECIAL DESIGN.
- 3-JOINTS INSIDE METER VAULT SHALL BE EITHER THREAD, COMPRESSION, SILVER SOLDERED OR 95-5 TIN ANTIMONY SOLDER.
- 4-THE WATER METER SHALL BE PURCHASED FROM CITY OF LONGMONT WATER/ WASTEWATER DEPT. COORDINATE WITH THE DEPT. FOR TYPES OF METERS AT (303) 651-8469.
- 5-METER SETTER SHALL BE AS INDICATED IN CITY STANDARDS.
- 6-NO CONNECTIONS OR CHANGES IN PIPE DIAMETER SHALL BE MADE IN THE METER OR IN THE DISTANCE OF FIVE FEET ON EITHER SIDE OF METER VAULT.
- 7-HALF INCH OR LARGER CONDUIT MUST BE RUN FROM THE PIT TO THE CLOSET BLDG AND UP THE EXTERIOR OF THE BUILDING WALL A MIN. OF 4 FEET.
- 8-WHEN THE BACKFLOW DEVICE IS INSTALLED INSIDE THE BUILDING, THE PLUMBING WITHIN THE VAULT WILL BE MODIFIED TO ACCOMMODATE THE METER ONLY.
- 9-THE INSTALLATION OF WATER METER VAULTS IN STREETS, ROADWAYS, DRIVEWAYS, ALLEYS OR PARKING LOTS WILL NOT BE ALLOWED UNLESS APPROVED BY THE WATER ENGINEER.

1 1/2" - 2" DOMESTIC METER IN VAULT
NTS



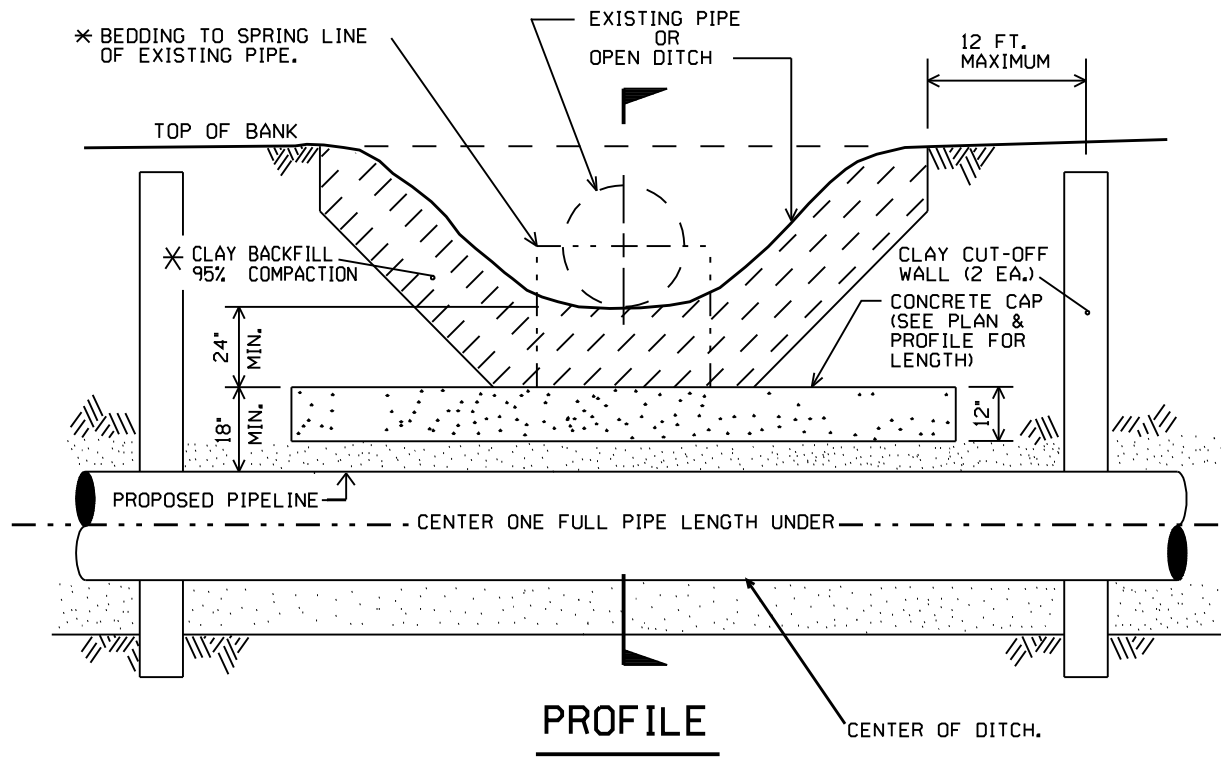

* USE CLAY BACKFILL ONLY WHEN CROSSING OPEN DITCH. USE BEDDING MATERIAL TO SPRING LINE OF EXISTING PIPE WHEN CROSSING PIPE.

DITCH CROSSING

(ALSO SEE DETAIL 100-05) NTS

REV 3-19-93 BM
REV 3-12-99 JR



500-10

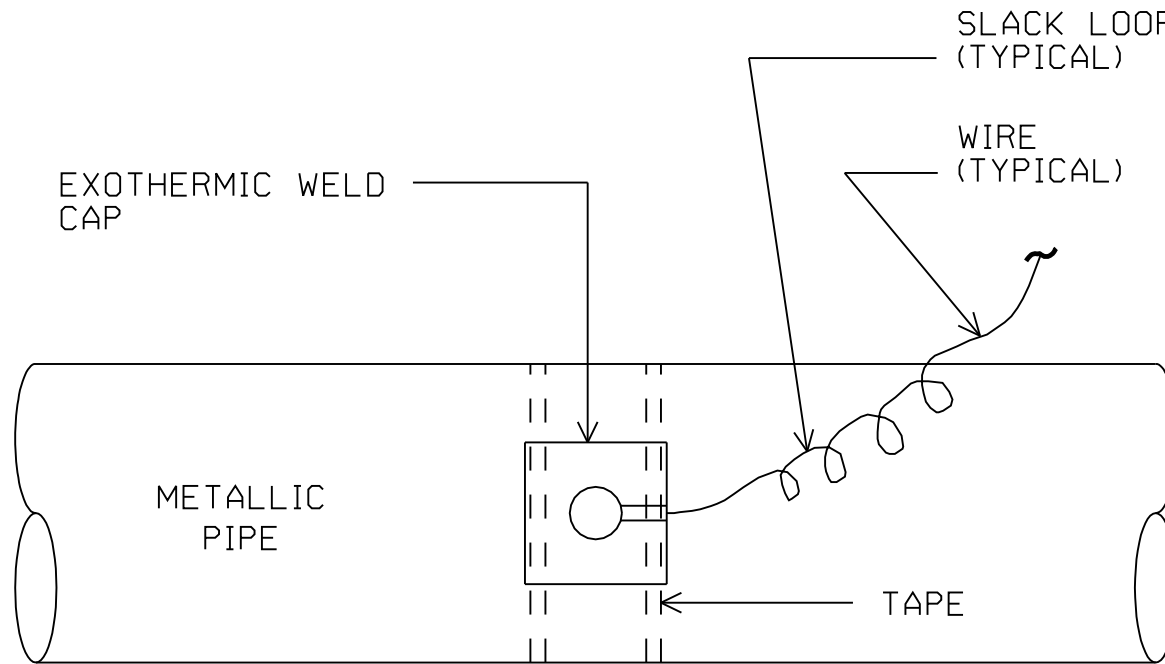

NOTES:
 THE EXOTHERMIC WELD CAP SHALL COMPLETELY COVER THE WIRE CONNECTION.

TAPE SHALL BE USED TO SECURE THE WELD CAP TO THE PIPE.

THE WELD CAP SHALL BE ORIENTED SO THAT THE WIRE SHALL BE RUN IN THE LONGITUDINAL DIRECTION OF THE PIPE.

EXOTHERMIC WELD CAP INSTALLATION



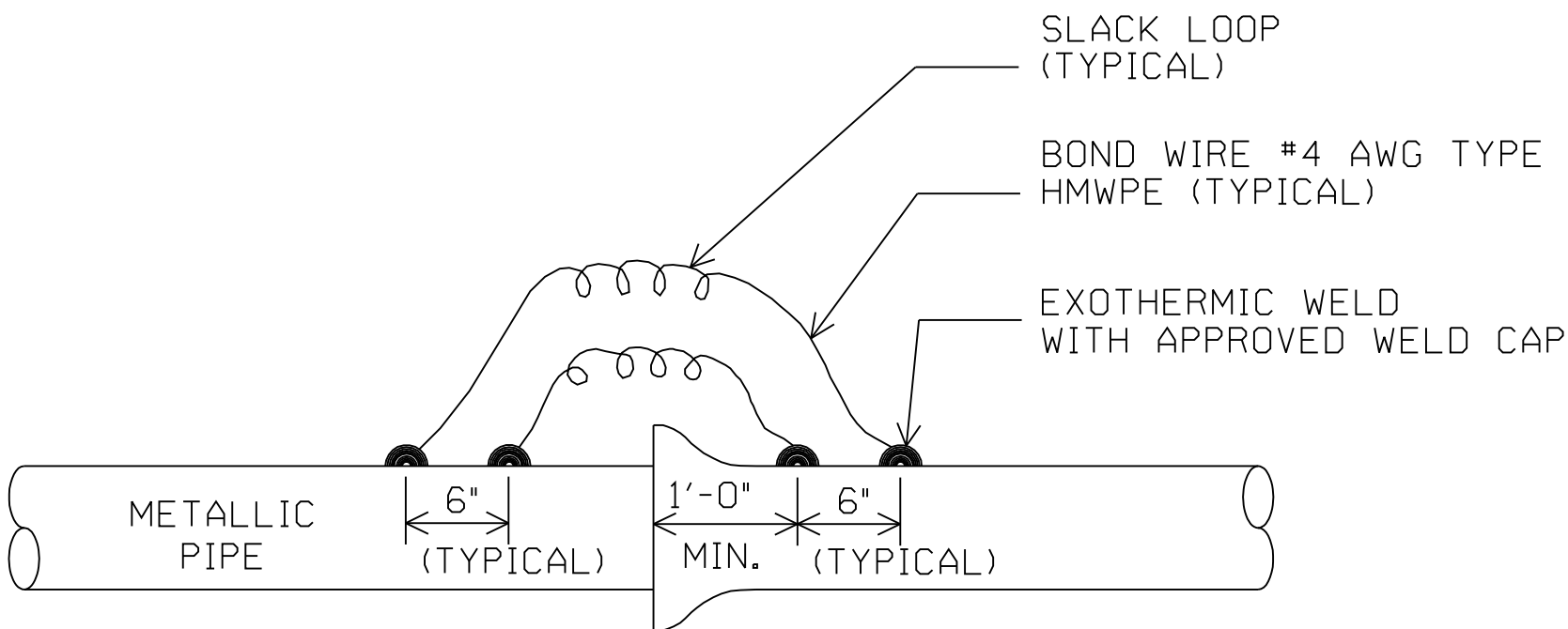

NOTE:
 BOND WIRES SHALL BE ATTACHED TO
 THE PIPE, VALVE OR FITTING TOP
 CENTERLINE.

JOINT BOND INSTALLATION

NTS



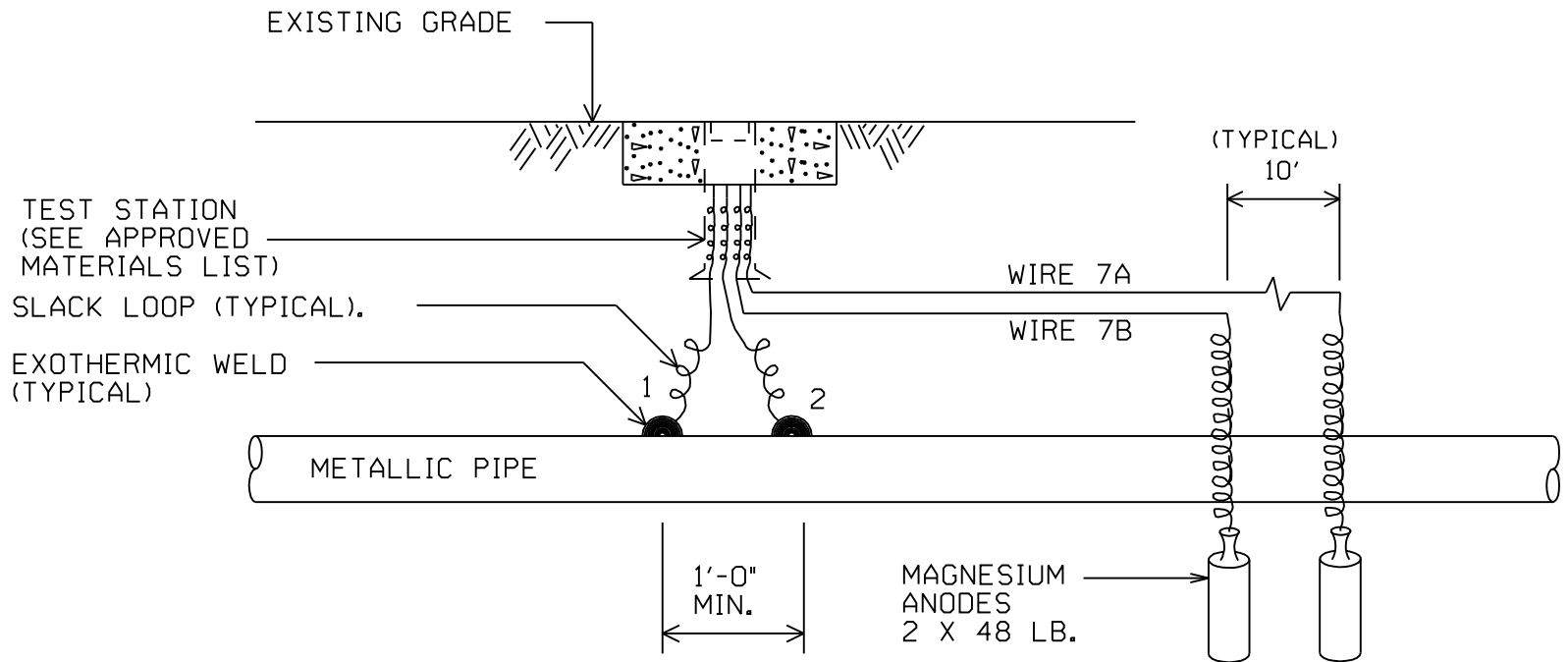

NOTES

- 1: ALL WIRES SHALL BE STRANDED COPPER TYPE RHW-2/RHH/USE-2.
- 2: A MINIMUM OF 24 INCHES OF SLACK SHALL BE INSTALLED IN EACH WIRE IN THE TEST STATION BOX.
- 3: ALL WIRES SHALL BE ATTACHED TO TOP OF PIPE.
- 4: ANODES ARE TO BE PLACED AT PIPE DEPTH OR BELOW AND 5 FEET AWAY FROM THE PIPE. INSTALL ON ALTERNATE SIDES OF THE PIPE.

**TEST STATION
TERMINAL BOARD
WIRING DETAIL.**

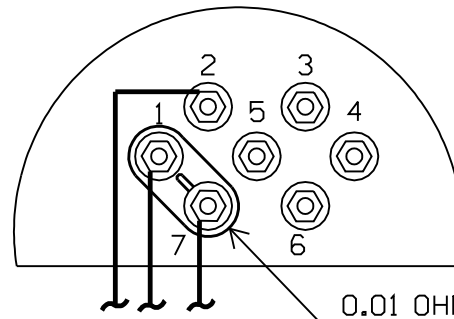

TERMINAL AND WIRE #	SIZE	COLOR
1	12 AWG	RED
2	12 AWG	RED
7(A&B)	12 AWG	BLACK

0.01 OHM-8 AMPERE SHUNT COLOR CODE- YELLOW COTT MANUF.

CATHODIC TEST STATION - TYPE 1

REV 1-02-02 JR
 REV 11-25-02 JR
 REV 03-04-03 JR

NTS



500-13

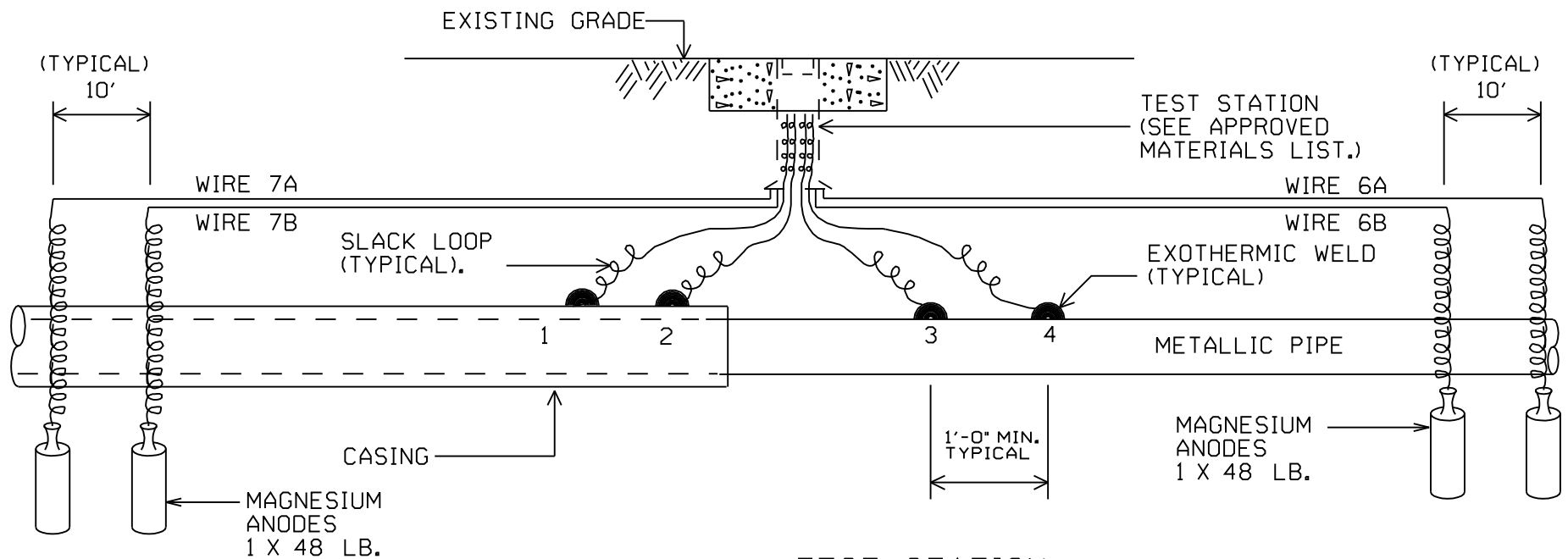

NOTES

- 1: A MINIMUM OF 24 INCHES OF SLACK WIRE SHALL BE INSTALLED FOR EACH WIRE IN THE TEST STATION BOX.
- 2: ALL WIRES SHALL BE STRANDED COPPER TYPE RHW-2/RHH/USE-2.
- 3: ALL WIRES SHALL BE ATTACHED TO THE PIPE TOP CENTERLINE.
- 4: ANODES ARE TO BE PLACED AT PIPE DEPTH OR BELOW AND 5 FEET AWAY FROM THE PIPE.

**TEST STATION
TERMINAL BOARD
WIRING DETAIL.**

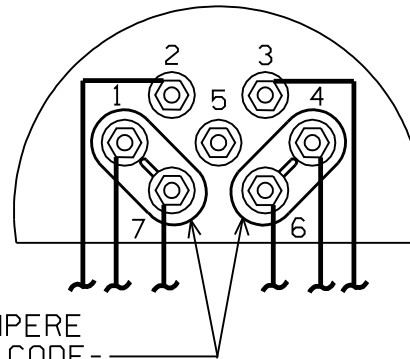

TERMINAL AND WIRE #	SIZE	COLOR
1	12 AWG	GREEN
2	12 AWG	GREEN
3	12 AWG	RED
4	12 AWG	RED
5	—	—
6 (A&B)	12 AWG	BLACK/RED
7 (A&B)	12 AWG	BLACK/GREEN

CATHODIC TEST STATION - TYPE 2

REV 1-03-02 JR
 REV 11-25-02 JR
 REV 03-04-03 JR

NTS



500-14

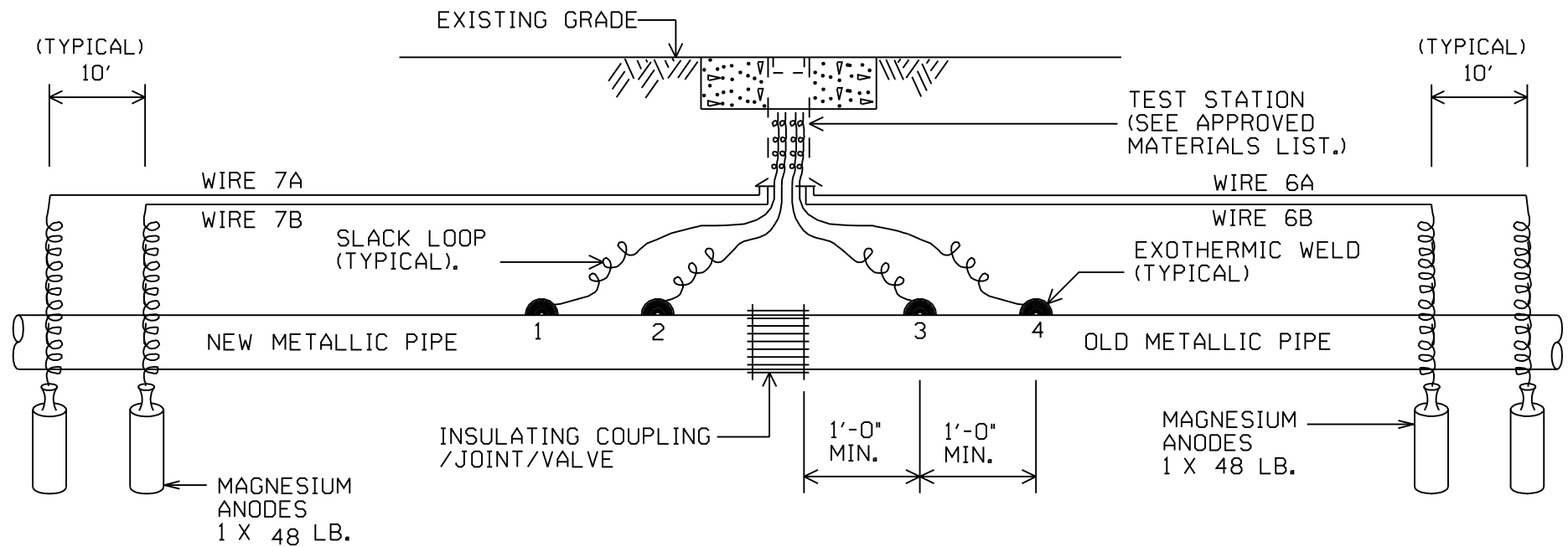

NOTES

- 1: A MINIMUM OF 24 INCHES OF SLACK WIRE SHALL BE INSTALLED FOR EACH WIRE IN THE TEST STATION BOX.
- 2: ALL WIRES SHALL BE STRANDED COPPER TYPE RHW-2/RHH/USE-2.
- 3: ALL WIRES SHALL BE ATTACHED TO THE PIPE TOP CENTERLINE.
- 4: ANODES ARE TO BE PLACED AT PIPE DEPTH OR BELOW AND 5 FEET AWAY FROM THE PIPE.

TEST STATION
TERMINAL BOARD
WIRING DETAIL.

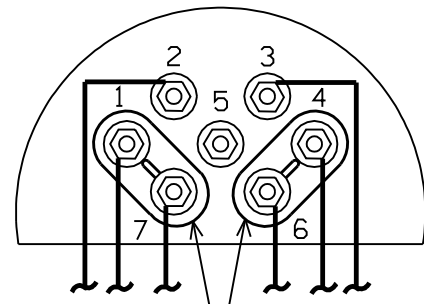

0.01 OHM-8 AMPERE
SHUNT COLOR CODE -
YELLOW COTT MANUF.

TERMINAL AND WIRE #	AWG SIZE	COLOR
1	12 AWG	RED
2	12 AWG	RED
3	12 AWG	BLUE
4	12 AWG	BLUE
5	—	—
6 (A&B)	12 AWG	BLACK/BLUE
7 (A&B)	12 AWG	BLACK/RED

CATHODIC TEST STATION - TYPE 3

REV 1-03-02 JR
REV 11-25-02 JR
REV 03-04-03 JR

NTS



500-15

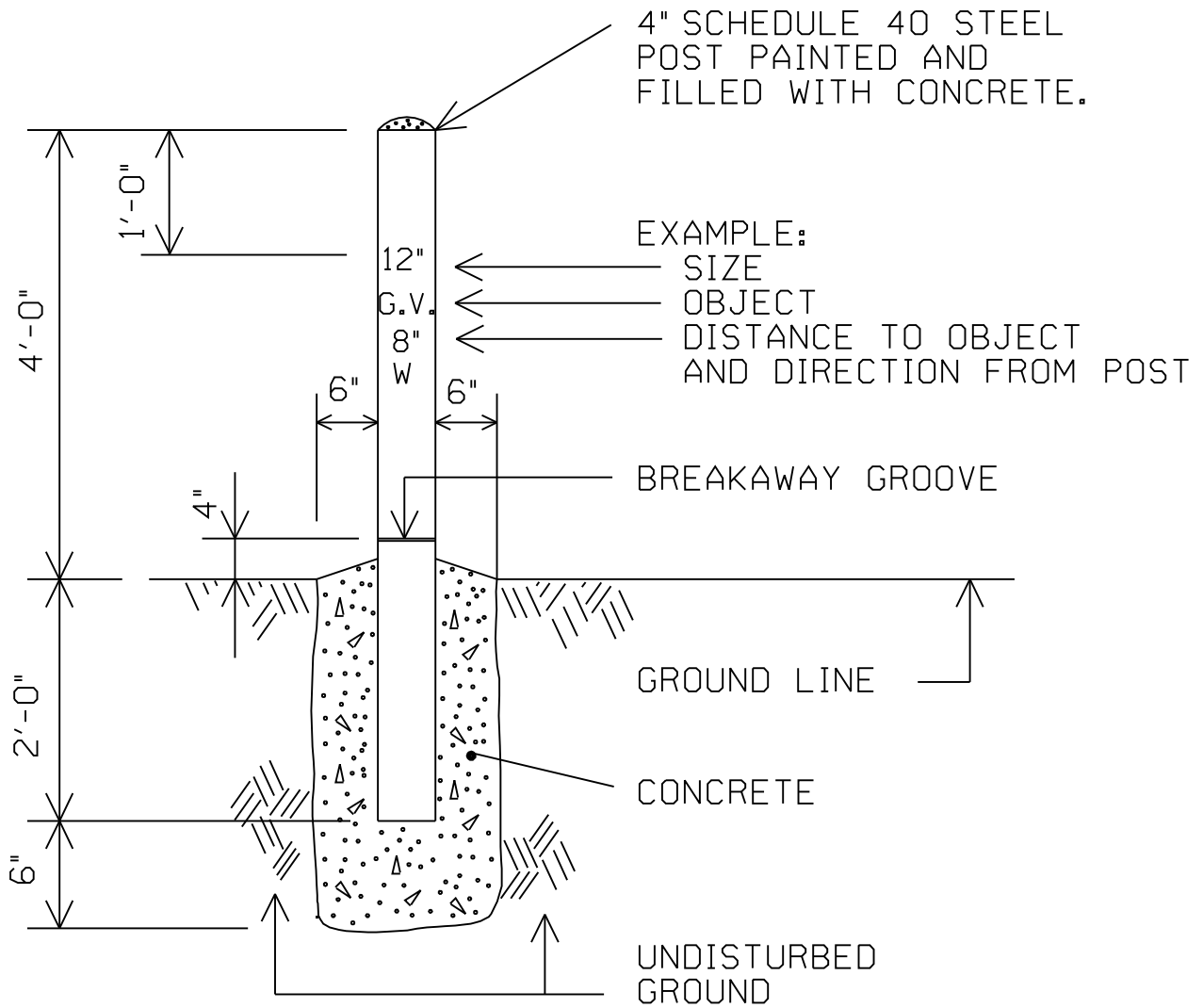

PAINT SCHEDULE

SAFETY YELLOW - CATHODIC PROTECTION

WHITE - POTABLE WATER PIPE, FITTINGS, VALVES

GREEN - SANITARY SEWER

NOTE: MARKER POSTS SHALL BE INSTALLED AT ALL FITTINGS, VALVES AND MANHOLES AS SHOWN ON THE PLAN.

MARKER POST

NTS



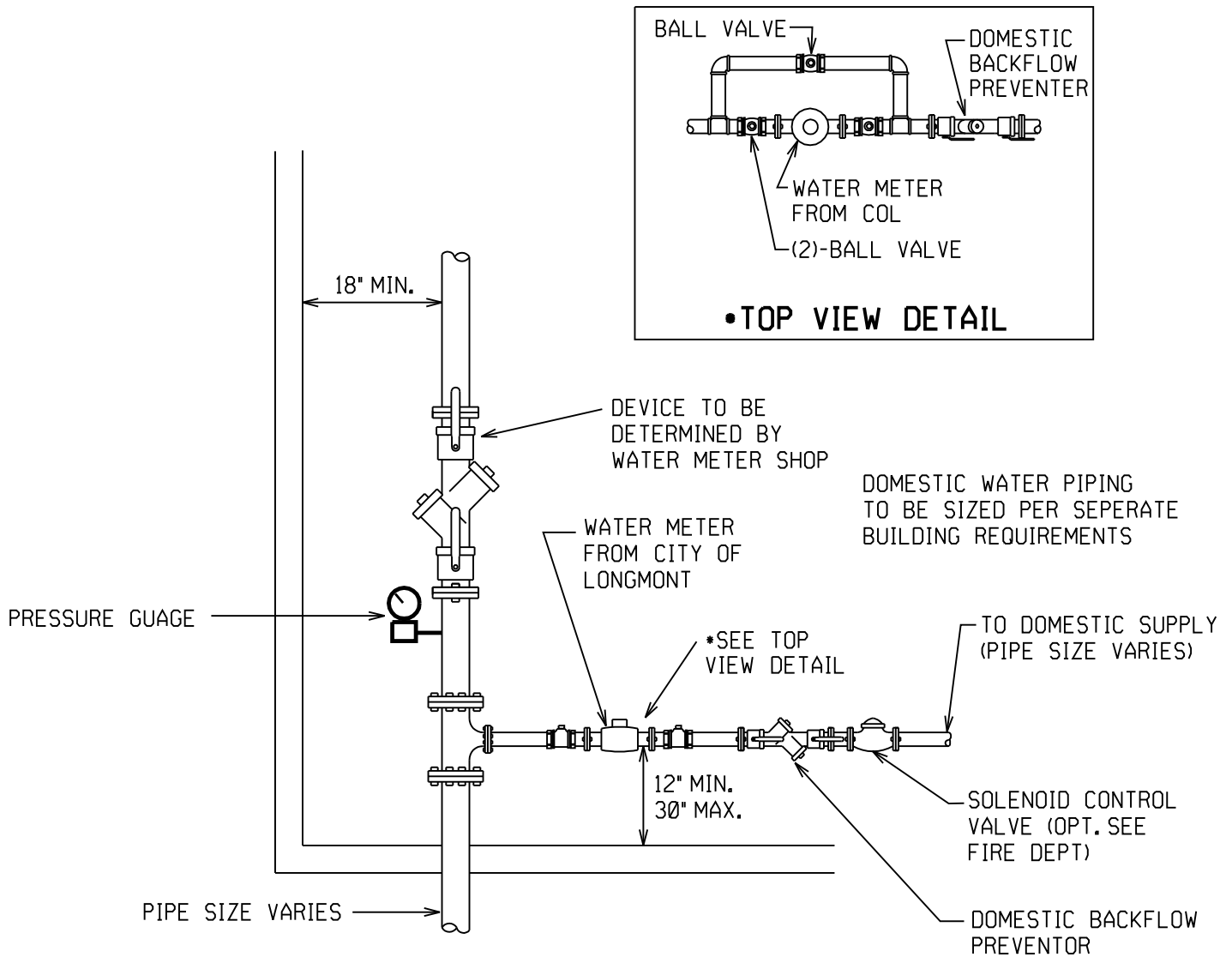

NOTES:

- 1-NO GALVANIZED FITTINGS ALLOWED
- 2-WATER METER AND BACKFLOW DEVICES PURCHASED FROM COL
- 3-ALL PIPE AND FITTINGS TO BE BRASS OR COPPER
- 4-1" METER WILL HAVE A REMOTE ON OUTSIDE OF BUILDING
- 5-1½" - 2" AMR 530.04 INSTALLATION SECTION 17, 18.

**FIRE/DOMESTIC WATER SUPPLY
COMBINATION DETAIL
¾" - 2" /MULTI FAMILY**

NTS



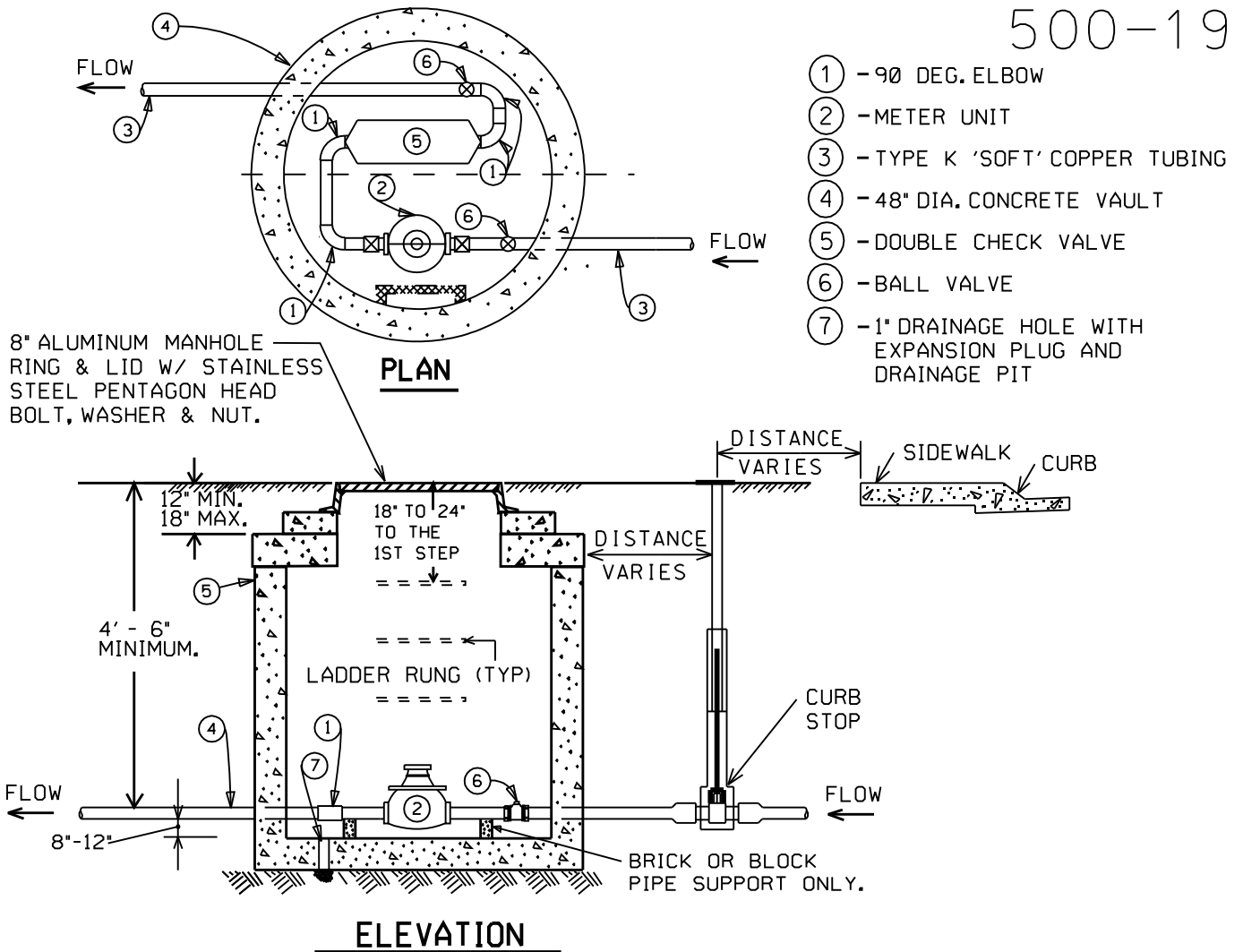

NOTES:

- 1-BASE AND BOTTOM BARREL SECTION SHALL BE PRECAST AS A SINGLE UNIT. THE VAULT SHALL BE WATERTIGHT. USE APPROVED GASKET MATERIALS TO SEAL PIPE PENETRATIONS.
- 2-JOINTS INSIDE METER VAULT SHALL BE EITHER THREAD, COMPRESSION, SILVER SOLDERED OR 95-5 TIN ANTIMONY SOLDER.
- 3-THE WATER METER SHALL BE PURCHASED FROM CITY OF LONGMONT WATER/WASTEWATER DEPT. COORDINATE WITH THE DEPT. FOR TYPES OF METERS AT (303) 651-8469.
- 4-METER SETTER SHALL BE AS INDICATED IN CITY STANDARDS.
- 5-NO CONNECTIONS OR CHANGES IN PIPE DIAMETER SHALL BE MADE IN THE METER OR IN THE DISTANCE OF FIVE FEET ON EITHER SIDE OF METER VAULT.
- 6-HALF INCH OR LARGER CONDUIT MUST BE RUN FROM THE PIT TO THE CLOSET BLDG AND UP THE EXTERIOR OF THE BUILDING WALL A MIN. OF 4 FEET.
- 7-WHEN THE BACKFLOW DEVICE IS INSTALLED INSIDE THE BUILDING, THE PLUMBING WITHIN THE VAULT WILL BE MODIFIED TO ACCOMMODATE THE METER ONLY.
- 8-THE INSTALLATION OF WATER METER VAULTS IN STREETS, ROADWAYS, DRIVEWAYS, ALLEYS OR PARKING LOTS WILL NOT BE ALLOWED UNLESS APPROVED BY THE WATER ENGINEER.

3/4" - 1" DOMESTIC METER IN VAULT
NTS

