



385 Kimbark Street, Longmont, CO 80501
T 303-651-8332 F 303-651-8930
building.inspection@longmontcolorado.gov

How to Use this Guide

Provide pdf files by email or a USB/flashdrive and complete the following:

- 1 Complete this Building Guide by filling in the blanks on page 8, and indicating which construction details will be used.
- 2 Provide an ILC (Improvement Location Certificate), Plot/Site Plans showing dimensions of your project and its relationship to existing buildings or structures on the property and the distance to existing property lines drawn to scale.
- 3 Fill out a building permit application.
The majority of permit applications are processed with little delay once complete. The submitted documents will help determine if the project is in compliance with building safety codes, zoning ordinances and other applicable laws.

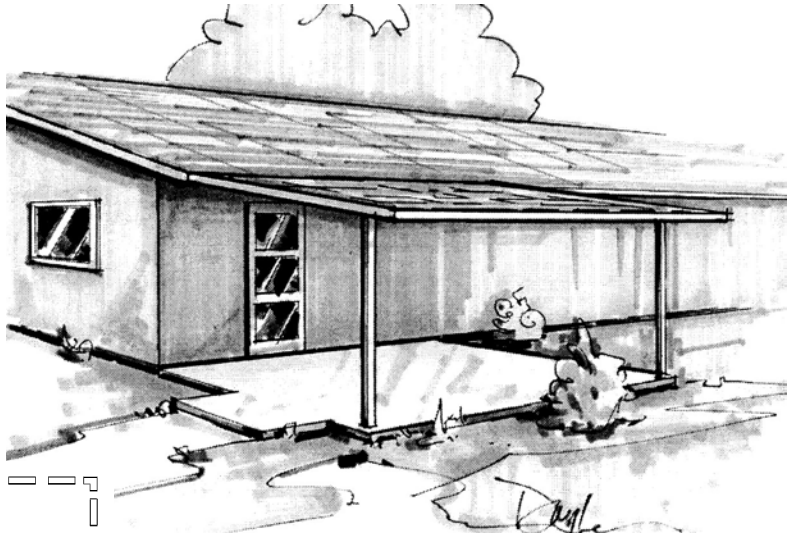

Important:
Do not alter existing drainage pattern. Prevent run-off water from crossing onto adjoining properties!

Single Family Residential Patio Covers, Pergolas & Carports

General Permit Information

A building permit is required anytime there is an addition, alteration, repair or demolition to the main structure or accessory structure on a lot or parcel.

The issuance of permits and subsequent inspections of the work performed ensures all construction in the city is safe and in compliance with the City of Longmont Land Development Code and the adopted International Residential Code (IRC). The primary purpose of this codes is to ensure a safe and healthy environment for the residents of Longmont.

Permits are reviewed and issued at the Building Services Office located at the Development Services Center, 385 Kimbark St. The office is open from 8:00 am to 5:00 pm Monday – Friday, closed on holidays. Call 303-651-8332 for more information.

As a homeowner, you may act as your own contractor and work on the property where you reside without a contractor's license. You may subcontract parts of a project, and anyone you hire must be insured and licensed with the City of Longmont. In addition, you are responsible for obtaining inspections and written approvals on the permit.

EXCEPTION: electricians and plumbers are also licensed by the state and must obtain permits for all work they do, and can attach to a homeowner or contractor's permit once licensed in Longmont.

CAUTION: If you do work, or have any work done without obtaining a permit, you could be incurring liability in the event of a fire or accident related to the work. In some circumstances, your insurance could be

Please note:

Noise: Section 10.20.100 of the Longmont Municipal Code prohibits making unreasonable noises which would cause a person of ordinary sensitivities significant annoyance or irritation. Noise associated with construction is limited to the hours of 7:00am-7:00pm Mon – Sat and not before 9:00am on Sunday.

Construction Debris and Trash: The Longmont Municipal Code requires debris and trash to be contained on the job site.

Before Digging: ALWAYS call the Utility Information Center at 811 or 1-800-922-1987 to locate underground utility lines. Allow 3 working days for the lines to be located and marked.

Single Family Residential Patio Covers, Pergolas & Carports

Scheduling Inspections

Requests for inspection may be made online at:

<https://aca.ci.longmont.co.us/CitizenAccess/Longmont.aspx> or voicemail at 303-774-4595.

You will need your permit number or you can search online by address. Inspections scheduled before 4:00 pm can be done on the following business day.

No inspections will be scheduled on subcontracted work done by an unlicensed subcontractor.

Your site address and permit must be posted on-site throughout the project.

You should not proceed to cover-up any work that has not been inspected. Although you may request either morning or afternoon inspection times, it is usually not possible to schedule a specific time for the inspector to be there. You SHOULD NOT schedule any concrete or other major work for the same day as the inspection. In the event the inspection fails, there could be costly ramifications. Inspections must be called in the day before needed in order to allow for efficient scheduling and routing of the Field Inspectors.

Please have all animals, including dogs, under control and NOT in the areas to be inspected. Inspections may not be made if there are animals running loose and a re-inspection fee may be required if this occurs.

Most patio covers and carports require three inspections. Pergolas usually require two inspections. Please use the following information to plan for these.

CAISSONS AND PIERS

- ✓ Approved plans posted on site

FRAMING INSPECTIONS

- ✓ Approved plans posted on site.
- ✓ All framing, fire blocking and bracing has been completed, which will be covered up at final inspection.

FINAL INSPECTION

- ✓ All framing work done and approved.

Single Family Residential Patio Covers, Pergolas & Carports

Plans

All construction drawings must be legible and submitted in pdf or a USB/flashdrive. Plans must either be drawn to scale or with all dimensions clearly shown. The following plans are required:

ILC (Improvement Location Certificate) or SITE/PLOT PLAN

1. North Arrow
2. Property Address
3. Lot Dimensions
4. Easements and adjoining street names
5. Parking and sidewalk locations
6. Location of proposed and existing structures including house, detached garages, sheds and deck. Show dimensions and distances to property lines and all other buildings on property.
7. Location of utility lines including water, sewer, electric and gas lines if affected by project.
8. Drainage pattern, if affected by project.

STRUCTURAL AND LAYOUT PLAN VIEW

1. Overall dimensions
2. Dimensions of footings/caissons (8" diameter if caissons)
3. Depth of footings/caissons below grade (30" minimum)
4. Beam size and bearing locations
5. Post anchor size

FRAMING/ARCHITECTURAL PLAN

1. Grade and species of all wood framing members
2. Size, span and spacing of joists, beams and posts
3. Size and species of decking materials
4. Bracing details
5. Finish grade with slope shown
6. Show dimensions
7. Location and size of stairs and guardrail and window wells
8. If involved in project, show: Electrical shown on plans including outlets, switches, fixtures and electrical service entrance location. (especially if affected by new structure)

Single Family Residential
Patio Covers, Pergolas & Carports

Sample ILC / Site Plan / Plot Plan

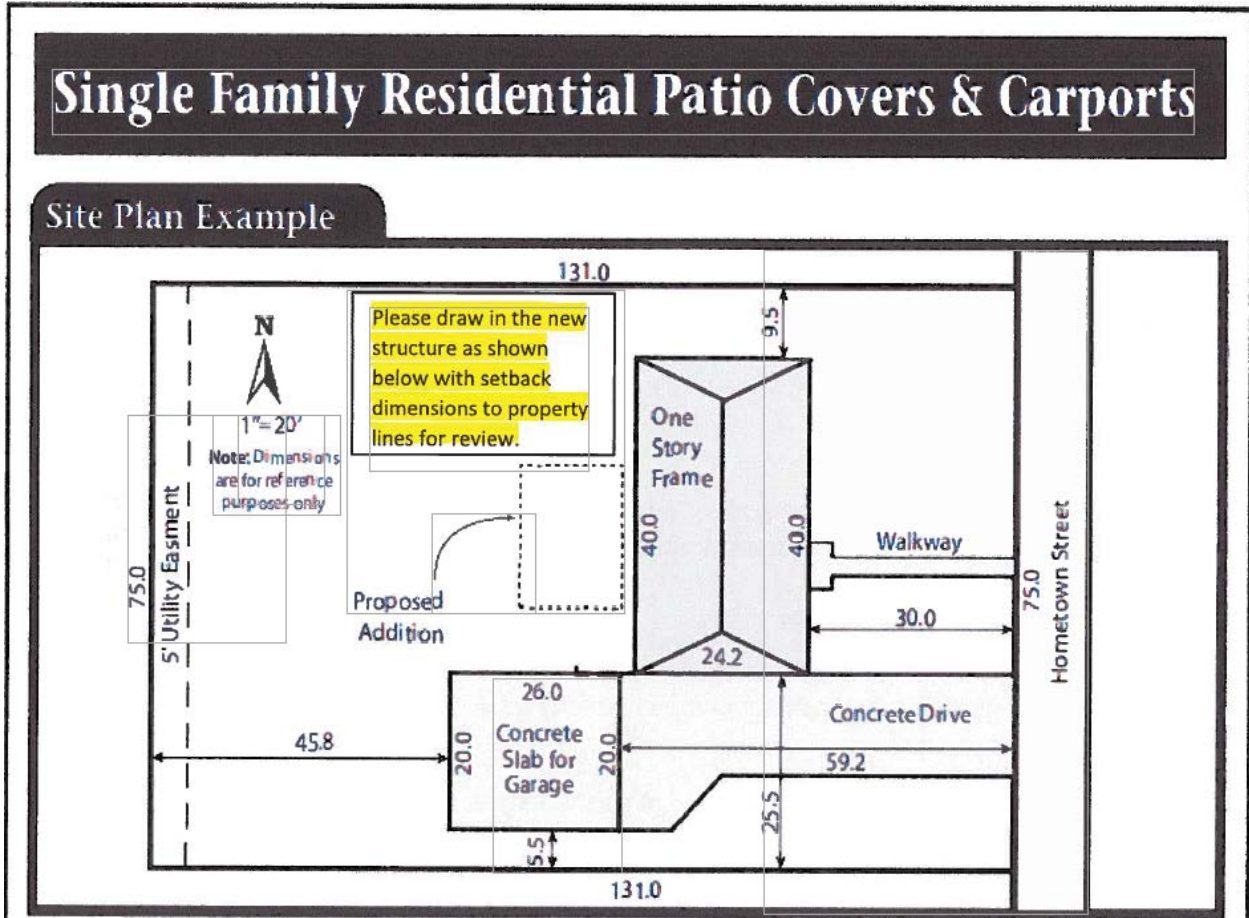

Single Family Residential Patio Covers, Pergolas & Carports

Information

SETBACKS

Structures which are *more than 24" above grade* must be placed within the minimum setback distances away from property lines, dependent upon the zone district in which they are located as specified in the Longmont Municipal Code Section 15.03.020.

RESIDENTIAL ZONE SETBACK REQUIREMENTS			
Zones	R-SF	R-MN	R-MF
Front Yard	20'	20'	20'
Rear Yard	20'	15'	10'
Side Yard	5'	5'	5'

WOOD SPECIES

Redwood is unsuitable for Structural Members (i.e. Beams, Joists and Ledger Boards, etc.) Redwood may be used for posts, roof sheathing more than 50% open, handrails and trim. Pressure treated or approved wood of natural resistance to decay must be used when the wood is in contact with concrete.

FOOTINGS/CAISSONS

The minimum depth is 30" to get below frost line; minimum width is 8". Footings/Caissons which support large loads, or constructed on poor soils may require different foundation designs.

POSTS

Posts are attached to the caissons below and the beams above with suitable anchors and brackets. Posts are 4"X4" minimum. Redwood may be used if it is relatively free of knots and splits. Otherwise, pressure treated lumber may be required.

LEDGER BOARD

The minimum ledger size shall be the same size as the rafters. Ledger boards are attached to the house with lag bolts that are at least 3/8" in diameter and long enough to go through the ledger board, siding, and they shall also penetrate fully into the rim joist or other backing inside the wall.

The new structure shall not bear on any part of a house cantilever.

SWAY/CROSS BRACING

These are placed diagonally between the posts and beams and may be required for covers and structures built high enough to cause sway.

Con't on next page

Single Family Residential Patio Covers, Pergolas & Carports

BEAMS AND RAFTERS

Beam and rafter sizes are determined by a 30 psf. live load and a 10 psf. dead load, in combination with span lengths and roof area supported. Because there are many combinations of span and roof area, this pamphlet will not attempt to address all of these. The minimum sizes will be verified with the aid of a computer program by the Building Inspection office upon review of your project.

BEAMS

Beams are attached to posts below with suitable metal ties. Beams may cantilever out from support posts a maximum of 1'-0". Beams may be either one solid piece of lumber or more commonly, two boards of equal size may be attached together forming one solid member.

RAFTERS

Rafters may be attached on top of the Ledger Board or to the side with joist hangers. They may be attached on top of the beams with solid blocking between them. Another method of attachment is with joist hangers in order to be "flush" on top with the top of beam. In this case it is required that the beam be either one solid piece or two or more boards securely fastened together to form one solid member.

50% MINIMUM OPEN ROOF COVERING

Two inch nominal wood including Redwood may be used for "slat type" roofing provided the space between allows for at least 50% openness for snow to fall out and not build up a snow load.

ROOF SHEATHING AND ROOFING

Please refer to the International Residential Code for information on plywood, particleboard sheathing, or roofing information. Asphalt shingles shall be installed per the amended IRC.

ELECTRIC METERS

Electric meter height must remain at 5'6" above grade. In the case of a deck, the finished floor of deck is considered grade.

Proper height of overhead service drop must be maintained:

- ⇒ A minimum of 10' at the service entrance to buildings, or above grade or any surface accessible by pedestrians.
- ⇒ A minimum of 3' above roofs with slopes greater than 3" in 12".
- ⇒ A minimum of 15' over driveways.

The meter may need to be moved in some instances.

TEMPERED GLASS

For tempered glass and hazardous locations, refer to the IRC.

DIRECTIONS ON FILLING IN THE FOLLOWING SECTION (see pages 8-11)

- 1 Fill in the blanks with dimensions and materials which will be used to build the structure. Please print legibly. For Pergolas, leave the roof section blank.
- 2 Indicate in the check boxes which details will be used. Please note if any of the sides of your carport addition are closer than 5'-0" to the property line, that side of the carport must be enclosed with a solid 1 hour fire rated wall as shown in Alternate Details B and C. You must however, keep at least two sides of the carport open to conform to the building code requirements. Please note that zoning approval is required.
- 3 Code compliant roofing materials must be installed per manufacturer's instructions, including low slope application and required inspections made.

Single Family Residential Patio Covers, Pergolas & Carports

Address: _____

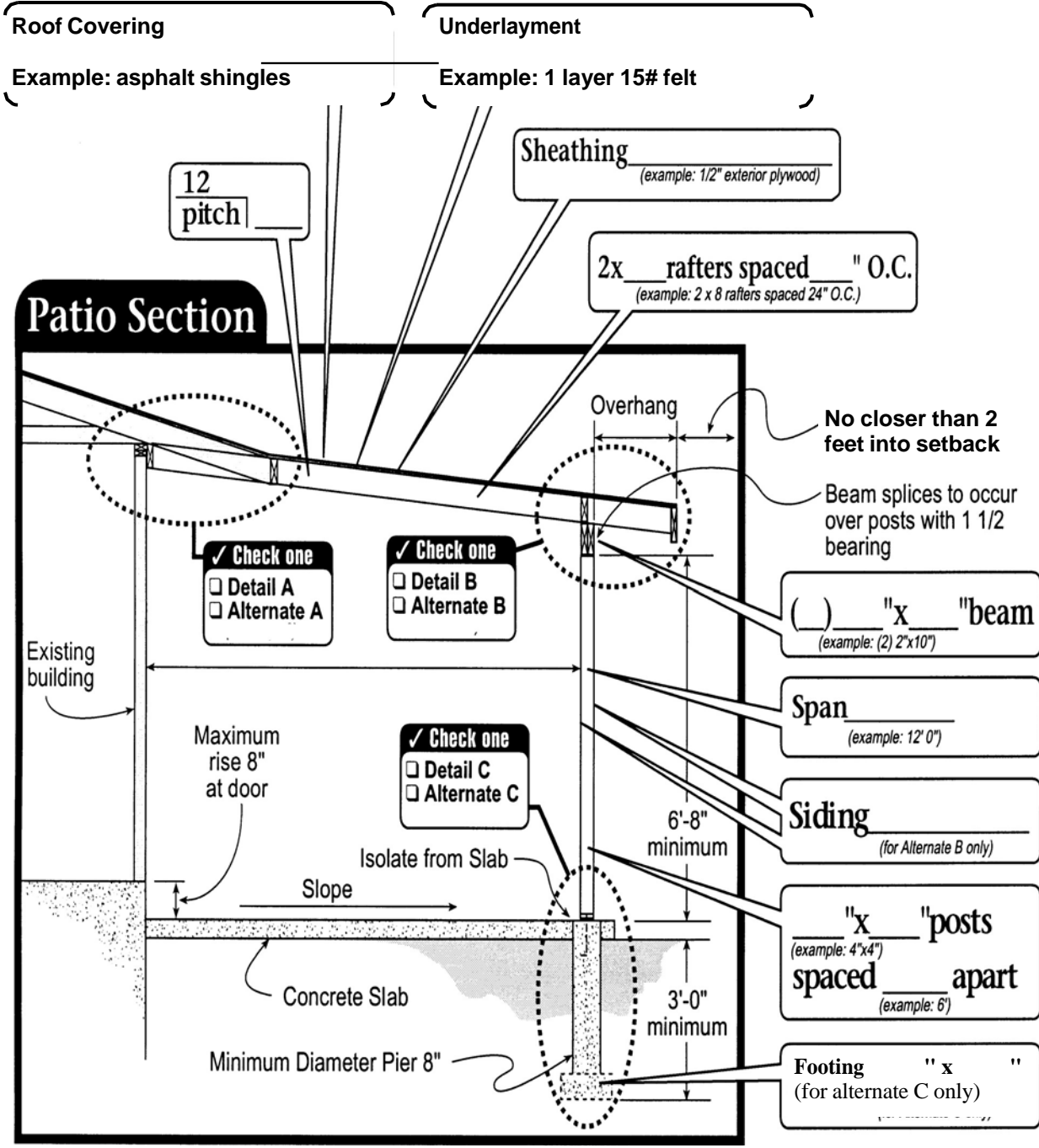

Single Family Residential Patio Covers & Carports

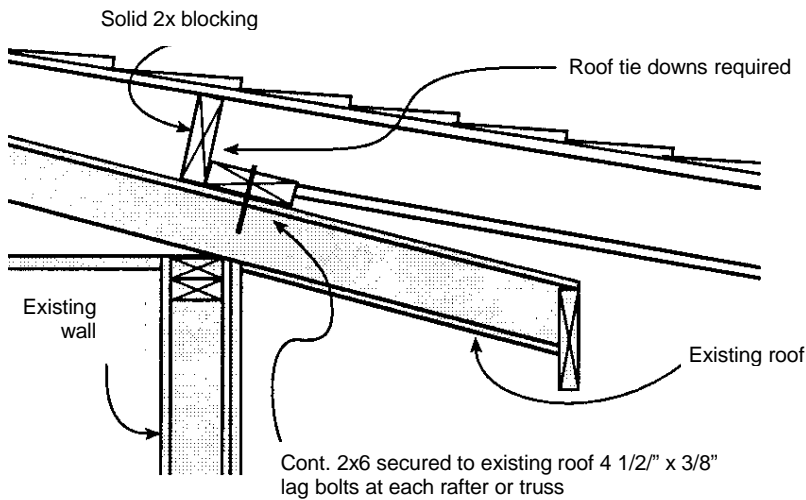
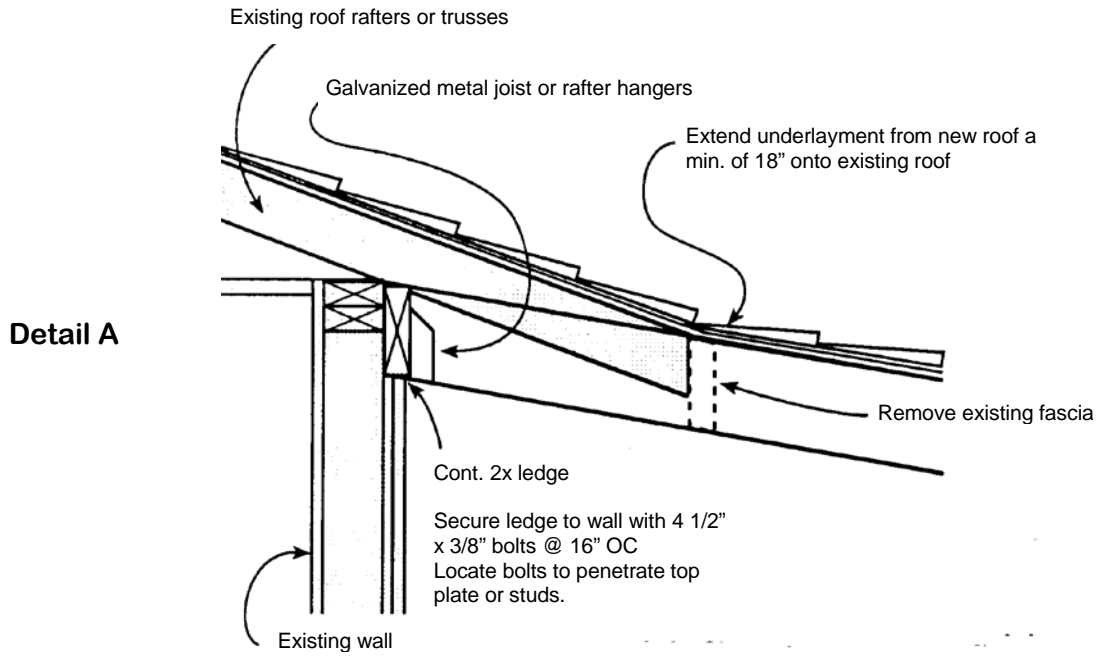

Alternate Detail A

Single Family Residential Patio Covers & Carports

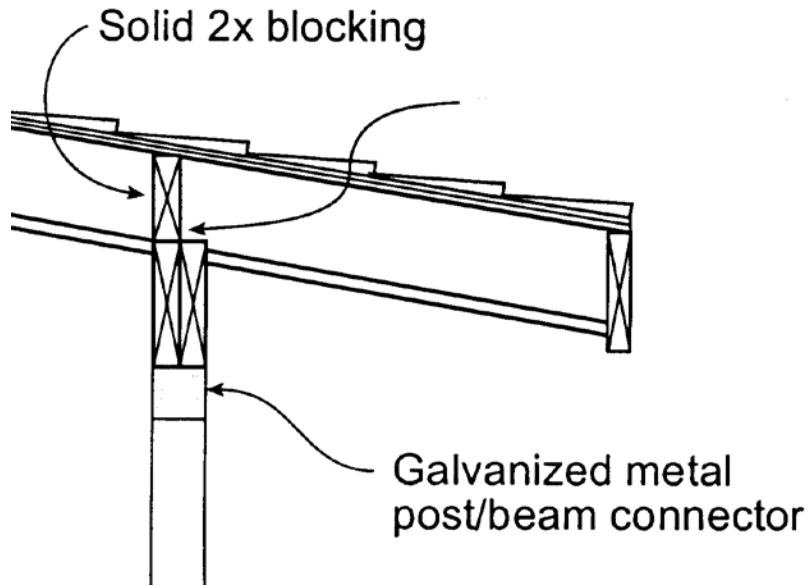

Detail B

Alternate Detail B

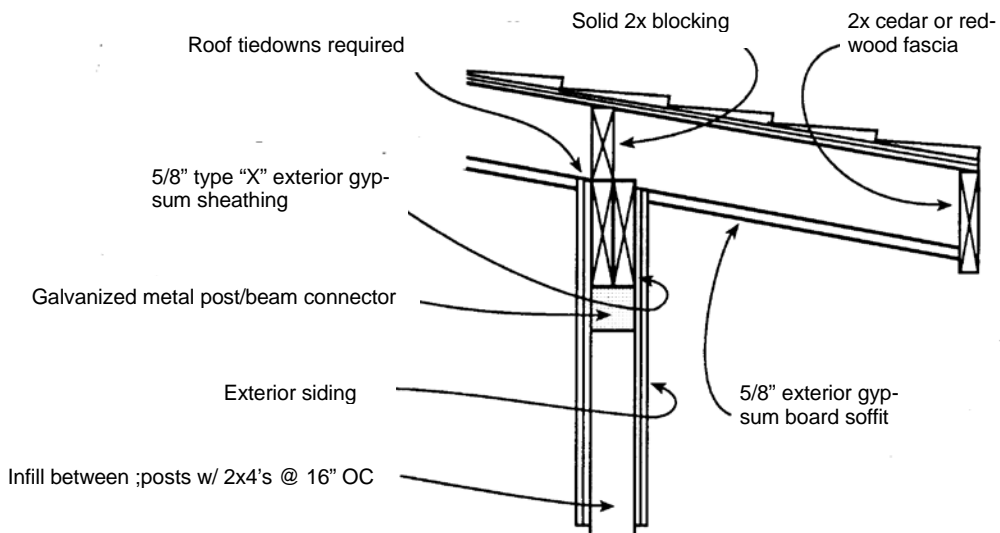

Single Family Residential Patio Covers & Carports

Detail C

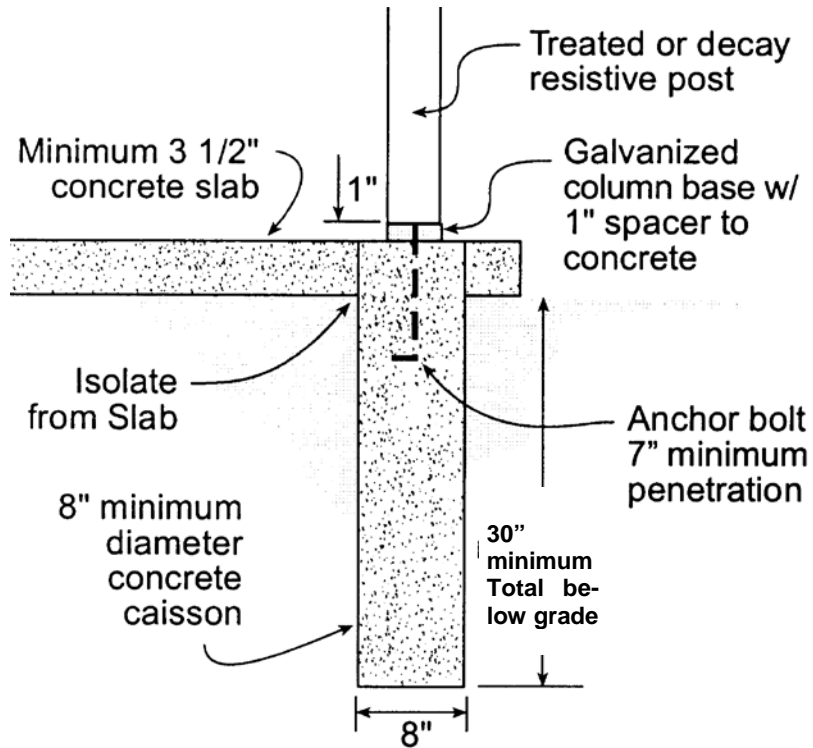

Bottom plate shall be treated wood or Foundation redwood with 1/2"x10" min. anchor bolts 4' OC max.

Infill between posts w/ 2x4's @ 16" O.C.

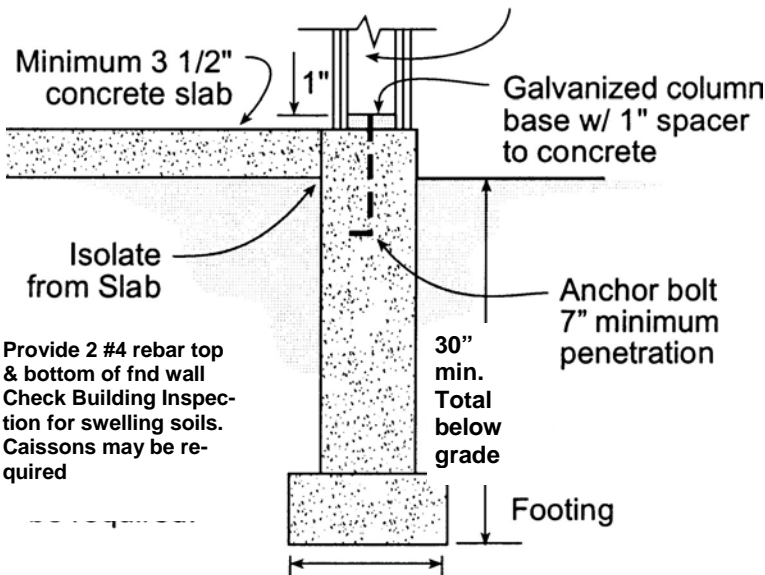

Alternate Detail C

Provide 2 #4 rebar top & bottom of fnd wall
Check Building Inspection for swelling soils.
Caissons may be required